

CD Stereo System

SC-AK90/SC-AK91

SC-AK70/SC-AK71

Operating Instructions

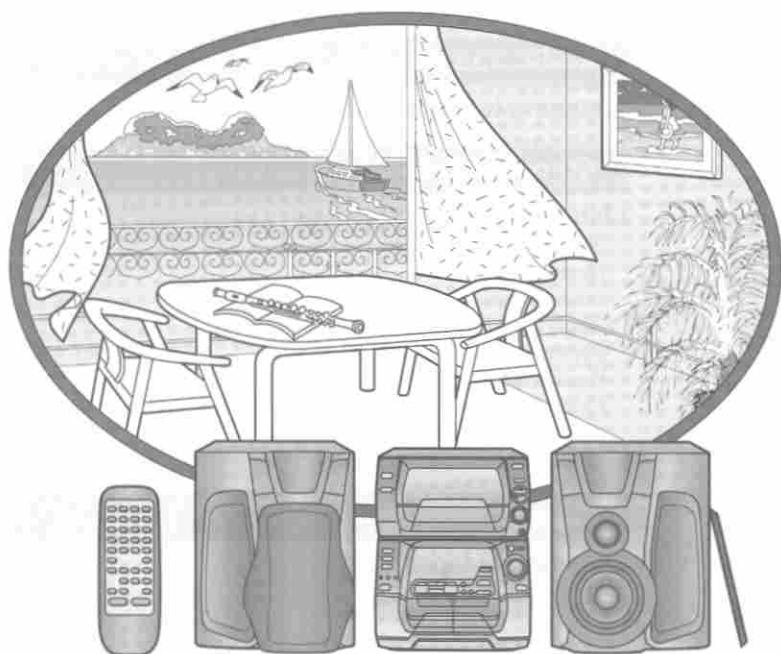

The illustrations show SC-AK90.

Panasonic®

P PC

COMPACT
disc
DIGITAL AUDIO

Before connecting, operating or adjusting this product, please read these instructions thoroughly. Please save this manual.

RQT3884-2P

Dear customer

Thank you for purchasing this product.
For optimum performance and safety, please read these instructions carefully.

These operating instructions are applicable to the following systems. These operating instructions, however, fundamentally explain the operation of system SC-AK90.

System	SC-AK90	SC-AK91	SC-AK70	SC-AK71
Main unit	SA-AK90	SA-AK91	SA-AK70	SA-AK71
Speakers	SB-AK90	SB-AK90	SB-AK70	SB-AK70

Note

System SC-AK91 and SC-AK71 are not available in Canada.

The model number and serial number of this product can be found on either the back or the bottom of the unit. Please note them in the space provided below and keep for future reference.

	MODEL NUMBER	SERIAL NUMBER
Main unit	_____	_____
Speakers	_____	_____

User memo:

DATE OF PURCHASE _____
DEALER NAME _____
DEALER ADDRESS _____
TELEPHONE NUMBER _____

CAUTION!

THIS PRODUCT UTILIZES A LASER.
USE OF CONTROLS OR ADJUSTMENTS OR PERFORMANCE OF PROCEDURES OTHER THAN THOSE SPECIFIED HEREIN MAY RESULT IN HAZARDOUS RADIATION EXPOSURE.
DO NOT OPEN COVERS AND DO NOT REPAIR YOURSELF. REFER SERVICING TO QUALIFIED PERSONNEL.

CAUTION:

TO PREVENT ELECTRIC SHOCK MATCH WIDE BLADE OF PLUG TO WIDE SLOT, FULLY INSERT.

Table of Contents

Before use

Supplied accessories	2
Precautions	4
Concerning the remote control	5
Connections	6
Basic connections (for supplied accessories)	6
Placement of speakers	7
Optional surround speaker connections	7
External unit connection	7
Optional antenna connections	7
Front panel controls	8

Preparations

Demo function	9
Setting the time	9
Presetting radio broadcasts	10

Radio operations

Listening to radio broadcasts	11
-------------------------------------	----

CD operations

Listening to CDs	12
Setting/Removing CDs	12
Normal play	13
Direct access play	14
Single CD play	15
Repeat play	15
Random play	15
Program play	16
To listen to special CDs and tracks (CD MANAGER function)	18

Tape deck operations

Listening to tapes	20
--------------------------	----

Supplied accessories

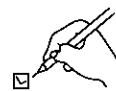

Please check and identify the supplied accessories. Use numbers indicated in parentheses when asking for replacement parts.

(Only for U.S.A.)

To order accessories call PASC Accessory Dept.
1-800-332-5368

- AC power supply cord 1 pc.
(SJA172)

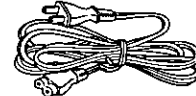

- FM indoor antenna (RSA0006) 1 pc.



- AM loop antenna set (RSA0022) 1 pc.
 • AM loop antenna 1 pc.
 • AM antenna holder 1 pc.

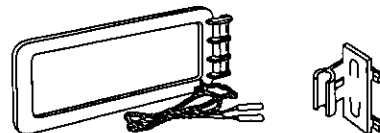

Recording operations

Before recording	21
Recording from radio broadcasts	22
Recording from CDs	23
To record special CDs and tracks (CD MANAGER function)	24
Tape-to-tape recording	26

Adjustments

Sound quality, field, etc.	27
---------------------------------	----

KARAOKE operations

Singing along with KARAOKE	28
----------------------------------	----

Timer operations

Timers	30
Using the play timer	31
Using the record timer	32
Using the sleep timer	33
To use two timers together	34

Other functions

Convenient functions	34
Using an external unit	35

Reference

Remote control buttons and functions	36
Concerning CDs	37
Concerning cassette tapes	37
Troubleshooting guide	38
Maintenance	39
Technical specifications	Back cover
Product service	Back cover
Before moving or shipping this system	Back cover

- | | | | |
|---|---|--|---------------------|
| <input type="checkbox"/> Notebook-like binder | 1 pc.
[Liner notes organizer]
(RFA0860-K) | <input type="checkbox"/> Adhesive number ... | 1 pc.
(RQLA0321) |
|---|---|--|---------------------|

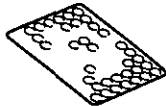
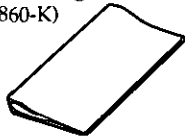

- | | | | |
|---|--|--|-----------------------------------|
| <input type="checkbox"/> Remote control transmitter | 1 pc.
SC-AK90/SC-AK91
(EUR644376) | <input type="checkbox"/> Batteries | 2 pcs.
(R6/LR6, AA size, UM-3) |
|---|--|--|-----------------------------------|

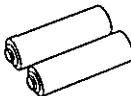
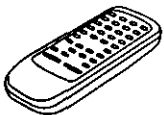

SC-AK70/SC-AK71
(EUR644375)



THE FOLLOWING IS APPLIED ONLY FOR U.S.A.:

CAUTION:

This equipment has been tested and found to comply with the limits for a Class B digital device, pursuant to Part 15 of the FCC Rules.

These limits are designed to provide reasonable protection against harmful interference in a residential installation. This equipment generates, uses and can radiate radio frequency energy and, if not installed and used in accordance with the instructions, may cause harmful interference to radio communications. However, there is no guarantee that interference will not occur in a particular installation. If this equipment does cause harmful interference to radio or television reception, which can be determined by turning the equipment off and on, the user is encouraged to try to correct the interference by one of the following measures:

- Reorient or relocate the receiving antenna.
- Increase the separation between the equipment and receiver.
- Connect the equipment into an outlet on a circuit different from that to which the receiver is connected.
- Consult the dealer or an experienced radio/TV technician for help.

FCC Notice: This system complies with new Part 15, except for the radio receiver, which complies with old Part 15, Subpart C of the FCC Rules. Operation is subject to the following two conditions: (1) This device may not cause harmful interference, and (2) this device must accept any interference received, including interference that may cause undesirable operation. The radio receiver is not subject to above item (2).

Any unauthorized changes or modifications to this equipment would void the user's authority to operate this device.

WARNING:

TO REDUCE THE RISK OF FIRE, ELECTRIC SHOCK OR PRODUCT DAMAGE, DO NOT EXPOSE THIS APPLIANCE TO RAIN, SPLASHING, DRIPPING OR MOISTURE.



CAUTION

**RISK OF ELECTRIC SHOCK
DO NOT OPEN**



CAUTION: TO REDUCE THE RISK OF ELECTRIC SHOCK, DO NOT REMOVE SCREWS. NO USER-SERVICEABLE PARTS INSIDE. REFER SERVICING TO QUALIFIED SERVICE PERSONNEL.



The lightning flash with arrowhead symbol, within an equilateral triangle, is intended to alert the user to the presence of uninsulated "dangerous voltage" within the product's enclosure that may be of sufficient magnitude to constitute a risk of electric shock to persons.



The exclamation point within an equilateral triangle is intended to alert the user to the presence of important operating and maintenance (servicing) instructions in the literature accompanying the appliance.

Precautions

Before using this unit please read these operating instructions carefully. Take special care to follow the warnings indicated on the unit itself as well as the safety suggestions listed below.

Afterwards keep them handy for future reference.

Safety

1. **Power Source**—The unit should be connected to power supply only of the type described in the operating instructions or as marked on the unit.
2. **Polarization**—If the unit is equipped with a polarized AC power plug (a plug having one blade wider than the other), that plug will fit into the AC outlet only one way. This is a safety feature. If you are unable to insert the plug fully into the outlet, try reversing the plug. If the plug should still fail to fit, contact your electrician to replace your obsolete outlet. Do not defeat the safety purpose of the polarized plug.
3. **Power Cord Protection**—AC power supply cords should be routed so that they are not likely to be walked on or pinched by items placed upon or against them. Never take hold of the plug or cord if your hand is wet, and always grasp the plug body when connecting or disconnecting it.
4. **Nonuse Periods**—When the unit is not used, turn the power off. When left unused for a long period of time, the unit should be unplugged from the household AC outlet.

Installation

Environment

1. **Outdoor Antenna Grounding**—If an outside antenna is connected to the receiver, be sure the antenna system is grounded so as to provide some protection against voltage surges and built-up static charges. Section 810 of the National Electrical Code, ANSI/NFPA No. 70-1990, provides information with respect to proper grounding of the mast and supporting structure, grounding of the lead-in wire to an antenna discharge unit, size of grounding conductors, location of antenna-discharge unit, connection to grounding electrodes, and requirements for the grounding electrode. See figure below.

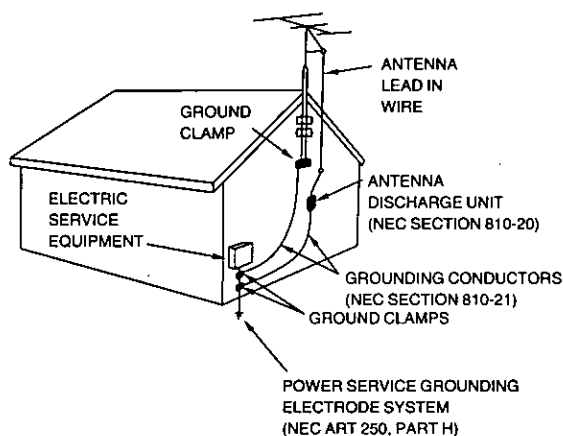

NEC—NATIONAL ELECTRICAL CODE

2. **Water and Moisture**—Do not use this unit near water—for example, near a bathtub, washbowl, swimming pool, or the like. Damp basements should also be avoided.

3. **Heat**—The unit should be situated away from heat sources such as radiators and the like. It also should not be placed in temperatures less than 5°C (41°F) or greater than 35°C (95°F).
4. **Condensation**—Moisture may form on the lens in the following conditions...
 - immediately after a heater has been turned on.
 - in a steamy or very humid room.
 - when the unit is suddenly moved from a cold environment to a warm one.If moisture forms inside this unit, it may not operate properly. To correct this problem, turn on the power and wait about one hour for the moisture to evaporate.

Placement

1. **Ventilation**—The unit should be situated so that its location or position does not interfere with its proper ventilation. Allow 10 cm (4") clearance from the rear of the unit.
2. **Foreign Material**—Care should be taken so that objects do not fall into and liquids are not spilled into the unit. Do not subject this unit to excessive smoke, dust, mechanical vibration, or shock.
3. **Magnetism**—The unit should be situated away from equipment or devices that generate strong magnetic fields.
4. **Stacking**—Do not place heavy objects, other than system components, on top of the unit.
5. **Surface**—Place the unit on a flat, level surface.
6. **Carts and Stands**—The unit should be used only with a cart or stand that is recommended by the manufacturer. The unit and cart combination should be moved with care. Quick stops, excessive force, and uneven surfaces may cause the unit and cart combination to overturn.
7. **Wall or Ceiling Mounting**—The unit should not be mounted to a wall or ceiling, unless specified in this operating instructions.



Maintenance

(See page 39 for details.)

Clean the cabinet, panel and controls with a soft cloth lightly moistened with mild detergent solution. Do not use any type of abrasive pad, scouring powder or solvent such as alcohol or benzene.

Service

1. **Damage Requiring Service**—The unit should be serviced by qualified service personnel when:
 - (a) The AC power supply cord or the plug has been damaged; or
 - (b) Objects have fallen or liquid has been spilled into the unit; or
 - (c) The unit has been exposed to rain; or
 - (d) The unit does not appear to operate normally or exhibits a marked change in performance; or
 - (e) The unit has been dropped, or the enclosure damaged.
2. **Servicing**—The user should not attempt to service the unit beyond that described in the operating instructions. All other servicing should be referred to an authorized service personnel. (Only for U.S.A.)
Call 1-800-545-2672 for the address of an authorized factory servicenter.

Listening caution



Selecting fine audio equipment such as the unit you've just purchased is only the start of your musical enjoyment. Now it's time to consider how you can maximize the fun and excitement your equipment offers. This manufacturer and the Electronic Industries Association's Consumer Electronics Group want you to get the most out of your equipment by playing it at a safe level. One that lets the sound come through loud and clear without annoying blaring or distortion—and, most importantly, without affecting your sensitive hearing.

We recommend you to avoid prolonged exposure to excessive noise.

Sound can be deceiving. Over time your hearing "comfort level" adapts to higher volumes of sound. So what sounds "normal" can actually be loud and harmful to your hearing.

Guard against this by setting your equipment at a safe level BEFORE your hearing adapts.

To establish a safe level:

- Start your volume control at a low setting.
- Slowly increase the sound until you can hear it comfortably and clearly, and without distortion.

Once you have established a comfortable sound level:

- Set the dial and leave it there.

Taking a minute to do this now will help to prevent hearing damage or loss in the future. After all, we want you listening for a lifetime.

Battery installation



Insert the batteries in the correct polarities (+, -).

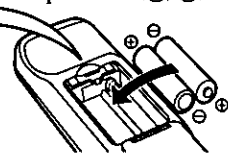

(R6/LR6
AA size, UM-3)

Use of batteries

- Do not mix old and new batteries, or batteries of different types (manganese and alkaline, etc.).
- Never subject batteries to excessive heat or flame; do not attempt to disassemble them; and be sure they are not short-circuited.
- If the remote control is not to be used for a long period of time, remove the batteries and store them in a cool, dark place.
- Do not attempt to recharge alkaline or manganese batteries.
- Do not use rechargeable type batteries.

Battery life

The battery life is about one year.

The batteries should be replaced if commands from the remote control transmitter do not operate the unit even when the transmitter is held close to the front panel.

Correct method of use

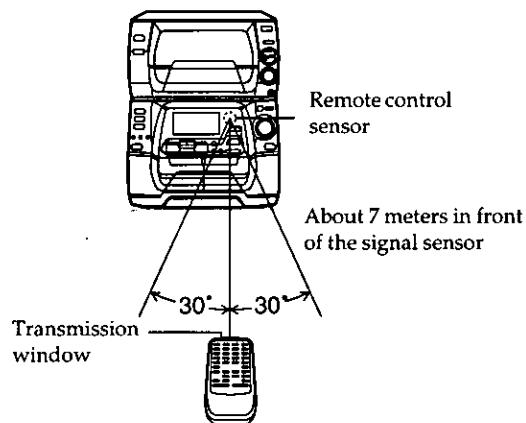

Operations notes

- Do not place obstacles between the remote control signal sensor and remote control unit.
- Do not expose the remote control signal sensor to direct sunlight or to the bright light of an inverter fluorescent light.
- Take care to keep the remote control signal sensor and end of the remote control unit free from dust.
- If this system is installed in a rack with glass doors, the glass doors' thickness or color might make it necessary to use the remote control a shorter distance from the system.

To prevent damage

- Do not place heavy items.
- Do not disassemble or reconstruct.
- Do not spill water or other liquids.

Basic connections (for supplied accessories)

Before making connections:

- Make sure you correctly identify the left / right sides before placing the speakers. (see page 7.)
- Plug the AC power supply cord into a household AC outlet only after all other connections have been made.

1 FM indoor antenna

Tape the antenna to a wall or column, in a position where radio signals are received with the least amount of interference.

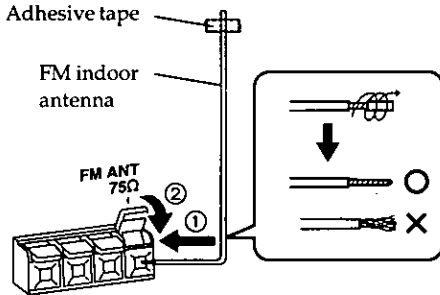

For best reception sound quality:
An FM outdoor antenna is recommended. (See page 7.)

2 AM loop antenna

After attaching the antenna, turn on the system and tune in a broadcast station. Then, turn the antenna to the angle of best reception and least interference.

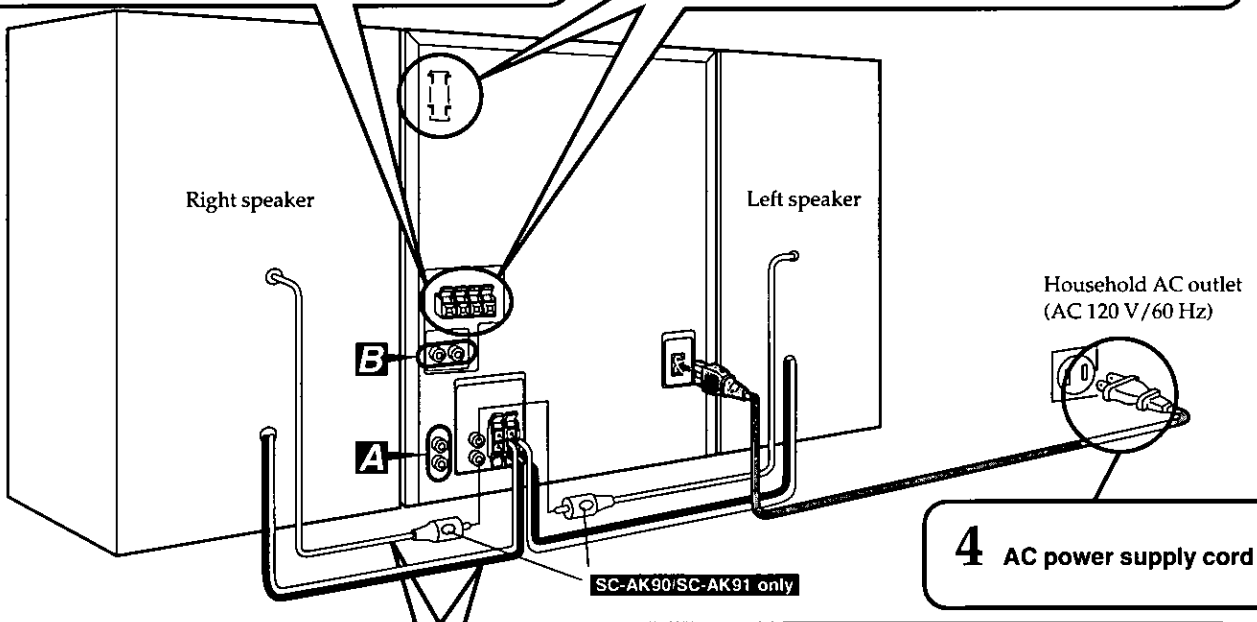
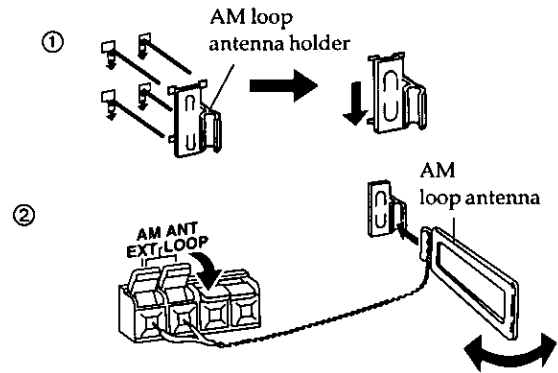

4 AC power supply cord

3 Speaker cords

Match the cords to the terminals by color and connect.

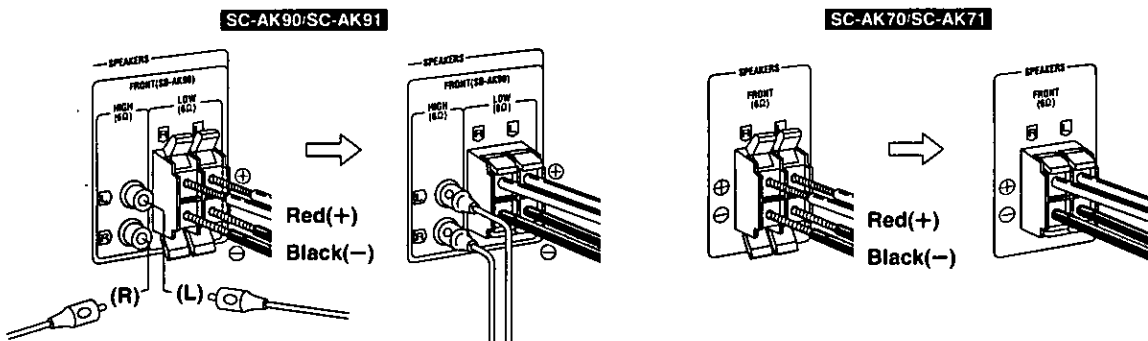

Note

To prevent damage to circuitry, never short-circuit positive (+) and negative (-) speaker wires.

Before use

Placement of speakers

Main units (included)

Front speaker (Left)
(included)

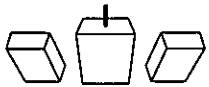

Front speaker (Right)
(included)

Surround speaker (Left)
(not included)

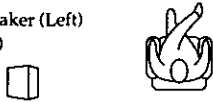

Surround speaker (Right)
(not included)

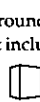

Placement of front speakers

SC-AK90/SC-AK91

Place the speakers so that the metal net is on the outside.

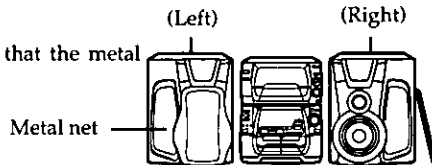

SC-AK70/SC-AK71

Place the speakers so that the midrange is on the outside.

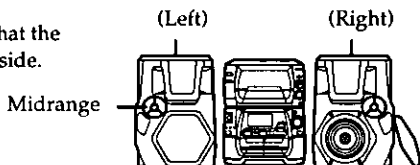

For your reference

- You can take the front net off speakers.
- For your listening pleasure, keep your speakers from touching the system.



Caution

Use the speakers only with the recommended system. Failure to do so may lead to damage to the amplifier and/or the speakers, and may result in the risk of fire. Consult a qualified service person if damage has occurred or if you experience a sudden change in performance.

Placement of surround speakers

We recommend that surround speakers be placed on the side of or slightly behind the listener at ear level. However the position should be adjusted to your personal preference, because the effect varies to some degree depending upon the type of music and the music source.

Optional surround speaker connections

Connecting the surround speakers produces a feeling of depth and movement of sound, and provides the listener with a feeling of presence like that of a movie theater.

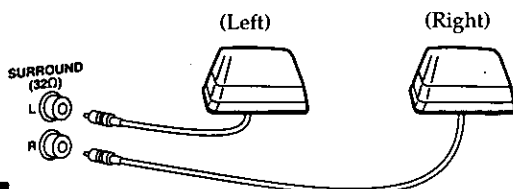

Note

If only one of the surround speakers is connected, no sound will come out. Be sure to connect both speakers.

External unit connection

- For details, refer to the instruction manual of the units which are to be connected.
- This example shows how to connect the analog player with the PHONO OUT/LINE OUT switch.
- When units other than those described below are to be connected, please consult with your audio dealer.

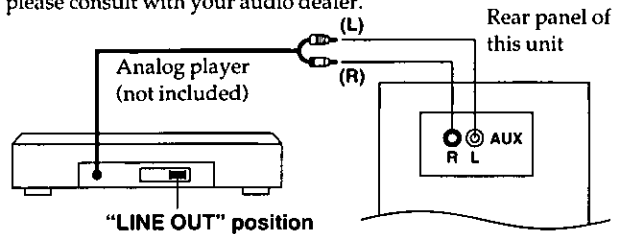

Note

- Only an analog player with a built-in phono equalizer can be connected.
- Set the switch to the "LINE OUT" position at the back of the analog player.

Optional antenna connections

You may need an outdoor antenna if you use this system in a mountainous region or inside a reinforced-concrete building, etc.

FM outdoor antenna

Disconnect the FM indoor antenna if an FM outdoor antenna is installed.

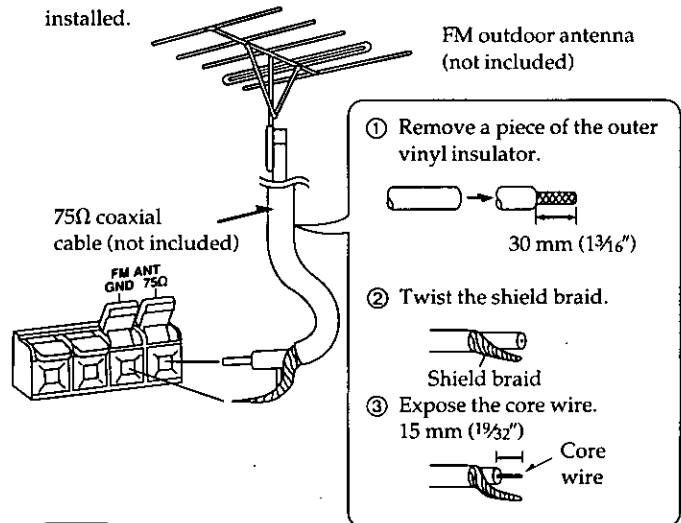

Note

An outdoor antenna should be installed by a qualified technician only.

AM outdoor antenna

Connect the outdoor antenna without removing the AM loop antenna. Run 5 to 12 m of vinyl-covered wire horizontally along a window or other convenient location.

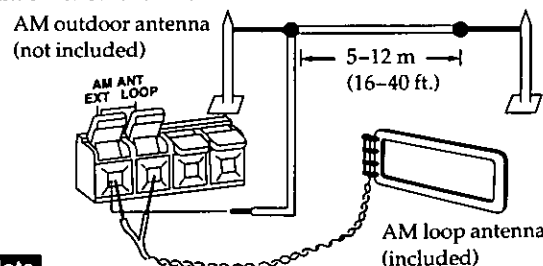

Note

When the unit is not in use, disconnect the outdoor antenna to prevent possible damage that may be caused by lightning. Never use an outdoor antenna during an electrical storm.

Front panel controls

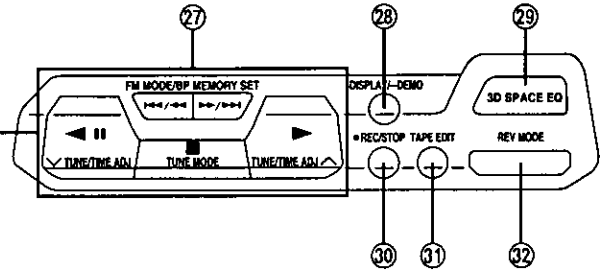
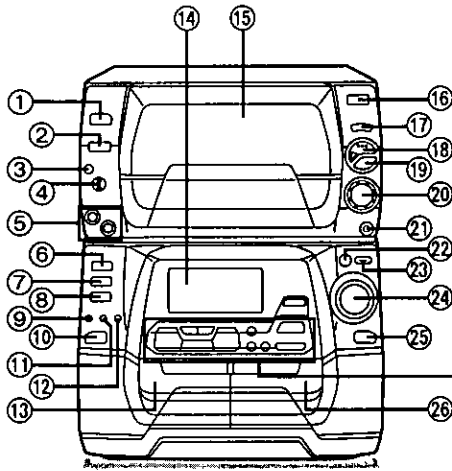

Before use

No.	Name	Ref. page
①	Power "STANDBY \odot /ON" switch (POWER, STANDBY \odot /ON)	9
②	Single play button (SINGLE \blacktriangleright)	15
③	SC-AK91/SC-AK71 only KARAOKE button (KARAOKE)	28
④	SC-AK91/SC-AK71 only Microphone volume control (MIC VOL)	28
⑤	SC-AK91/SC-AK71 only Microphone jacks (MIC 1, MIC 2)	28
⑥	CD button (CD)	13
⑦	Tuner/band select button (TUNER, BAND)	10
⑧	Tape/deck select button (TAPE, DECK 1/2)	20
⑨	AUX button (AUX)	35
⑩	Deck 1 open button (DECK 1, \blacktriangle OPEN)	20
⑪	Clock/timer button (CLOCK/TIMER)	9, 31, 32
⑫	Record timer/play timer button (\odot REC/ \odot PLAY)	31, 32
⑬	Deck 1 cassette holder	20
⑭	Display	
⑮	CD rack panel	12
⑯	CD rack panel open button (OPEN)	12
⑰	CD MANAGER button (CD MANAGER)	18
⑱	Disc/track select button and indicator (DISC/TRACK)	13, 14
⑲	Play button (CD \blacktriangleright)	13
⑳	Jog dial (JOG)	13, 14

No.	Name	Ref. page
㉑	Headphone jack (PHONES)	35
㉒	SC-AK90/SC-AK91 Super woofer ON/OFF button (SUPER WOOFER)	27
	SC-AK70/SC-AK71 V. BASS button (V. BASS)	27
㉓	SC-AK90/SC-AK91 only Super woofer level select button (LEVEL)	27
㉔	Volume control (VOLUME)	11
㉕	Deck 2 open button (DECK 2, \blacktriangle OPEN)	20
㉖	Deck 2 cassette holder	20
㉗	Basic operating buttons Buttons change according to the source.	
㉘	Display select/demonstration button (-DISPLAY/-DEMO)	9, 34
㉙	3D space EQ button (3D SPACE EQ)	27
㉚	Recording start/stop button (\bullet REC/STOP)	22
㉛	Tape edit button (TAPE EDIT)	26
㉜	Reverse mode select button (REV MODE)	20

Demo function

The demo function changes the display to simulate an airplane taking off from an airport.

Turning the demo function ON/OFF

Press POWER and hold down DISPLAY/DEMO.

Every time you hold down the button;

DEMO (ON) ↔ NO DEMO (OFF)

When the demo function is ON, the demo is played automatically in the following cases.

●When the system is ON

If the input source is set to CD or tape, and the system is left on standby for more than 2 minutes

●When the system is OFF

If the clock has not been set

Setting the time

This is a 12-hour display clock.

This example in the figure shows how to set the time for 6:25 p.m.

1 Switch on the power.

2 **1 Press CLOCK/TIMER to select "CLOCK".**

Every time you press the button;

CLOCK →  REC →  PLAY

← Previous display ←

2 (within 5 seconds or so)

Press MEMORY/SET.

3 **1 Press ∇ or \blacktriangle to select the hour.**

2 Press MEMORY/SET.

3 Press ∇ or \blacktriangle to select the minutes.

4 Press MEMORY/SET to finish setting the time.

The display will return to whatever was displayed before you set the time.

To display the time when power is ON

Press CLOCK/TIMER to select "CLOCK".

The time will be displayed for about 5 seconds and then the display will return to whatever was previously displayed.

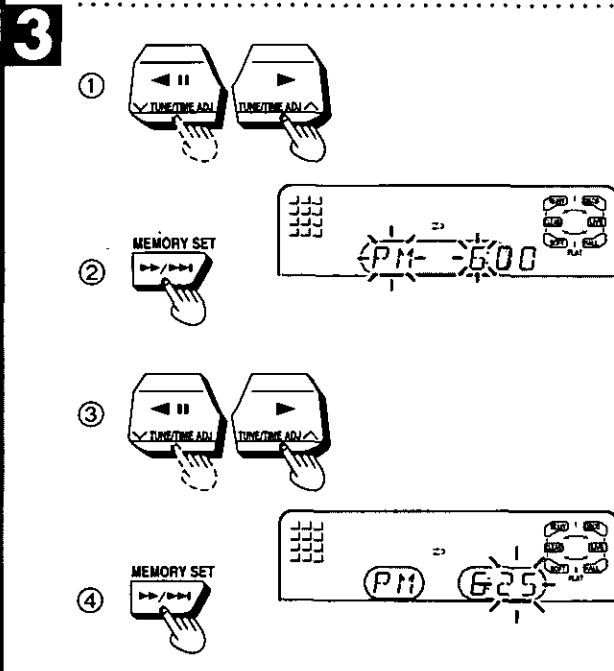
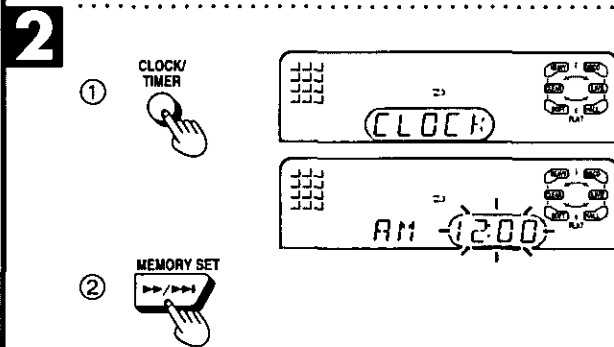
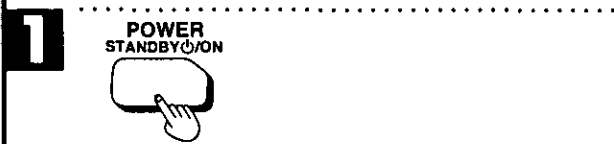
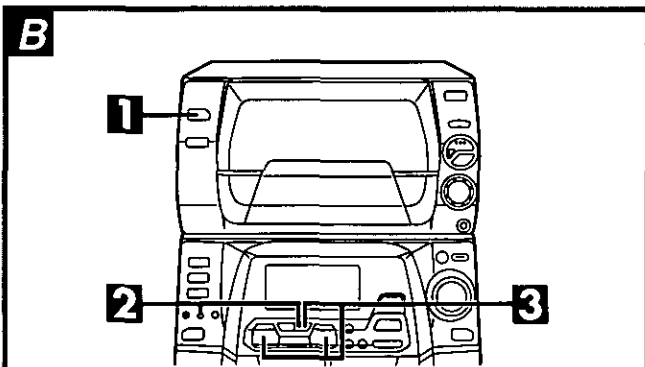
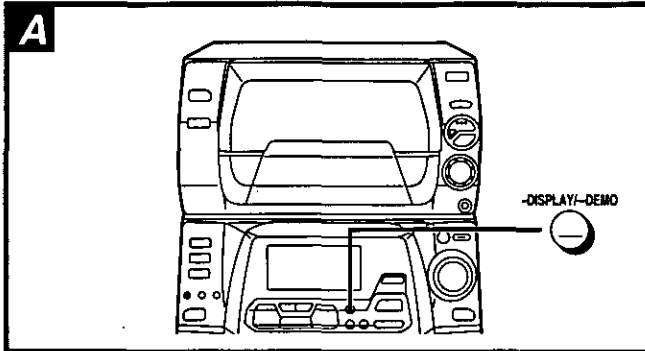

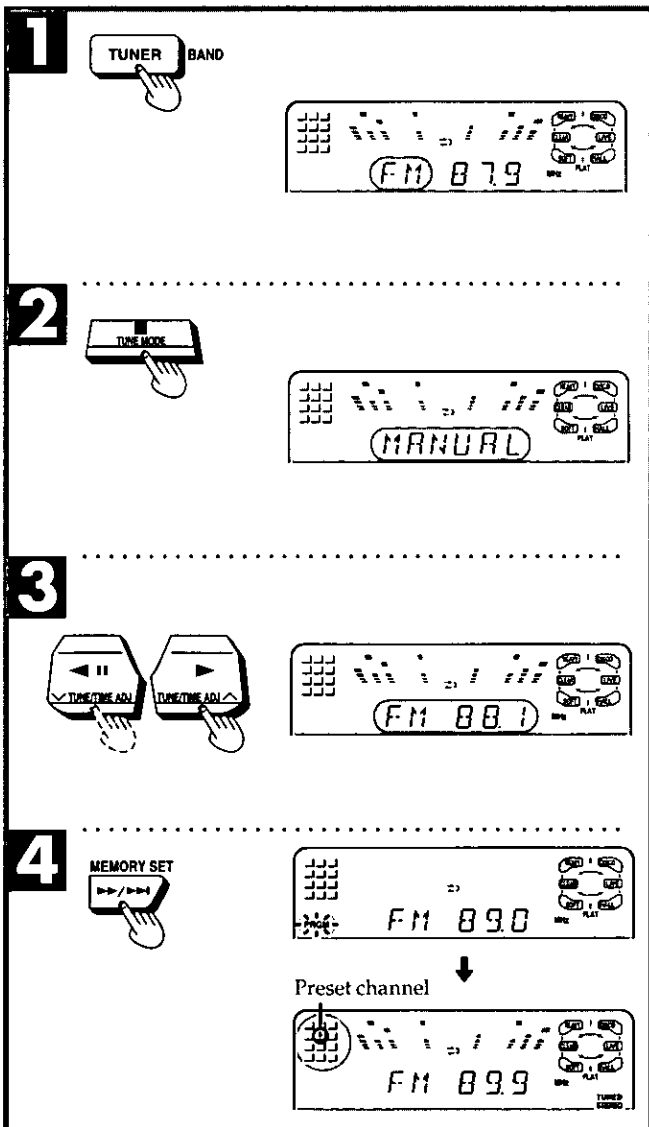
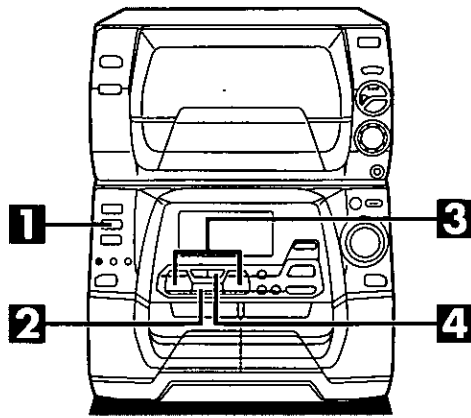

Presetting radio broadcasts

- Up to 12 stations can each be set in the FM and AM bands automatically.
- If broadcast frequencies are preset in the memory, you can easily tune in any of these frequencies from the system or remote control unit.
- You can also preset just those stations you like.
(See "Presetting only your favorite stations" below.)

- 1 Press TUNER BAND to select "FM" or "AM".**
The power will come on automatically.
Every time you press the button; "FM" ↔ "AM".
- 2 Press TUNE MODE to select "MANUAL".**
Every time you press the button; "MANUAL" ↔ "PRESET".
- 3 Press ∇ or \blacktriangle until the display shows the frequency from which you want to begin automatic memory presetting.**

Tips on tuning in radio stations

- ① Hold down either ∇ or \blacktriangle until the frequency numbers start scrolling.
- ② When nearing the desired frequency, press the button to stop the scrolling and then fine tune the broadcast.

- 4 Press and hold down MEMORY/SET until the frequency begins to change.**
This will start presetting automatically. When finished, the radio will tune in last station memorized.

If auto presetting is not possible because radio signals are weak or for some other reason, do the following.

Presetting only your favorite stations

Preset the stations one at a time.

1. Perform above steps 1 and 2. Then, select a station with ∇ and \blacktriangle , and press MEMORY/SET. "PRGM" will flash on the display.
2. While "PRGM" is flashing, select a preset channel with ∇ or \blacktriangle , and press MEMORY/SET again. "PRGM" will go out and the station will be stored in memory.

FM allocation setting

The FM frequency step is set to 0.2 MHz at the time of shipment. By adjusting the allocation as shown below, you can enable the system to receive FM broadcasts allocated in 0.1 MHz steps.

1. Press and hold TUNER BAND for approximately 5 seconds.
The frequency display will be returned to the minimum frequency of the FM band and the display will begin to flash.
Keep holding for approximately 5 more seconds.
2. When the display stops flashing and indicates a different frequency number (the frequency step is changed to 0.1 MHz.), release TUNER BAND.

To return to the original frequency, repeat steps 1 to 2 above.

Note

After changing the "allocation" setting, the frequencies you previously preset in the memory will be cleared.

Memory retention

Your preset frequencies are retained in memory for about 2 weeks while the system is unplugged.

Listening to radio broadcasts

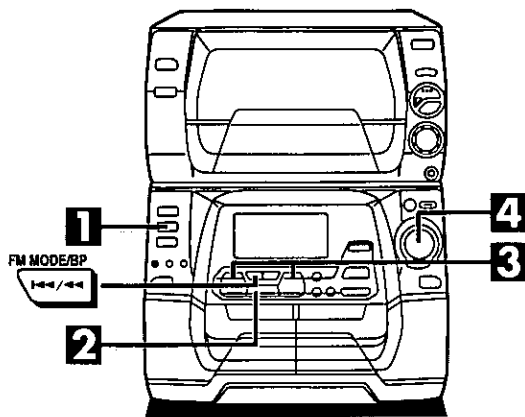

- 1** Press **TUNER BAND** to select "FM" or "AM".
The power will come on automatically.
Every time you press the button; "FM" ↔ "AM".
- 2** Press **TUNE MODE** to select "PRESET" or "MANUAL".
Every time you press the button; "MANUAL" ↔ "PRESET".
PRESET: For preset stations
MANUAL: For non-preset stations
- 3** Press **∇** or **∧** to select the desired broadcast.
"STEREO" lights when an FM stereo broadcast is being received. "TUNED" lights when you precisely tune in a broadcast station.
- 4** Adjust the volume level.

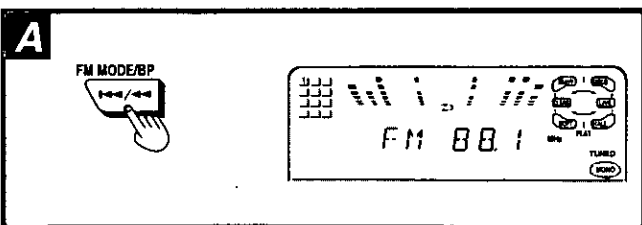
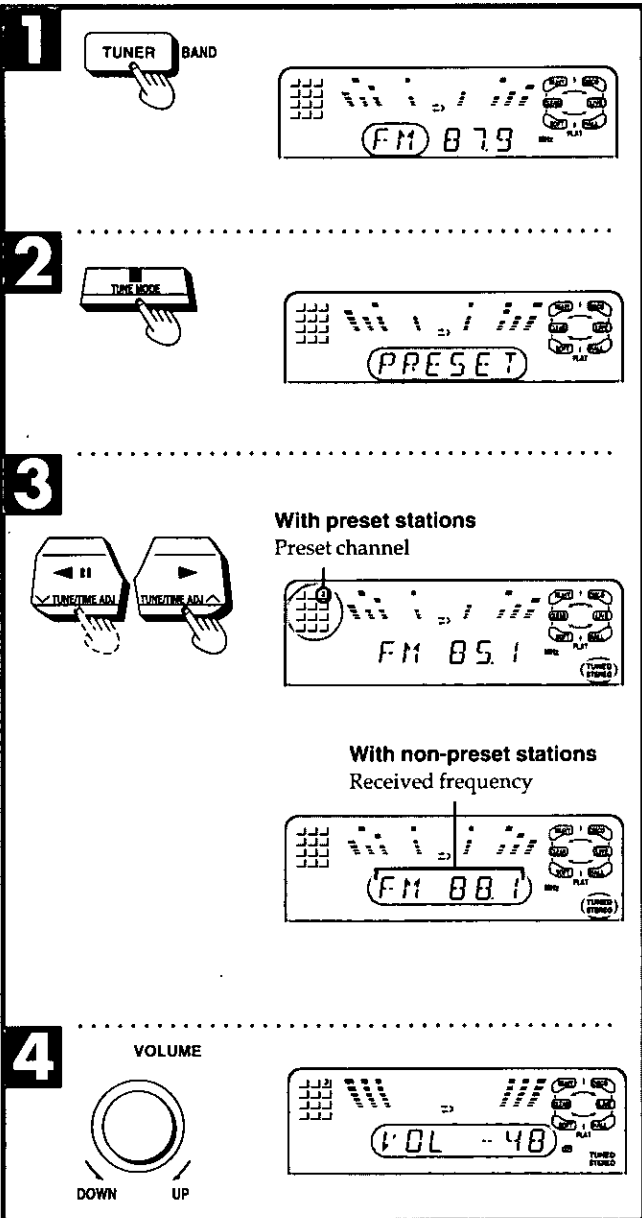

For tuning by remote control

Specify the channel you want with the numeric keys (see page 36).

To designate channels 1-9

Press the appropriate (1-9) preset-tuning button.

To designate channels 10-12

(Example: Channel 12)

≥10 → 1 → 2
(within 10 sec.) (within 10 sec.)

Auto tuning

Auto tuning is an easy way to tune in non-preset stations (select "MANUAL" in step 2).

Hold down either **∇** or **∧**, and release the button when the frequency starts scrolling.

The radio frequency will stop automatically on the first station it picks up.

- When there is outside interference, the radio may stop on a non-broadcast frequency. Hold down either **∇** or **∧** to resume auto tuning.

To stop auto tuning

Press either **∇** or **∧** again.

If noise is excessive in the FM stereo mode

Press **FM MODE/BP**. ("MONO" will light up.)

Sound will be produced in monaural, but this also reduces noise. Press the button again to cancel. "MONO" will go out.

Normally, you'll want to listen in stereo, so leave "MONO" off. This way, you can listen to stereo broadcasts in stereo, and monaural broadcasts in mono.

Note

Sound is momentarily interrupted if you load/unload tapes while listening to an AM broadcast.

Setting/Removing CDs

You can set CDs in the rack and remove them too, while playing CDs.

How to set CDs

1. Open the rack panel.

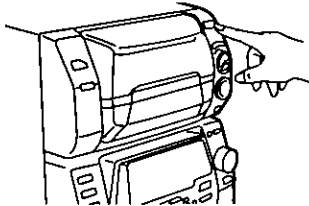

Note

Except when setting or removing CDs, keep hands out of the changer while open. You could injure yourself if somehow entangled in the internal mechanism.

2. Slide the loader carriage to the slot you want.

Note

The loader carriage has a LOCK position (when the lever is down) and a RELEASE position (when the lever is up). When you slide the loader carriage to select the slot you want, make sure it is in the RELEASE position (when the lever is up). You can read the numbers between the prongs as shown below.

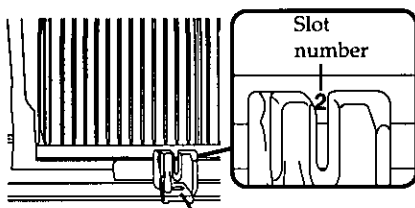

Loader carriage

Slot No. 0 (SINGLE) is reserved for single CD play (p. 15).

3. ① Lower the lever on the loader carriage and set the CD in the groove with the label facing to the right.

- ② Raise the lever.

Label side

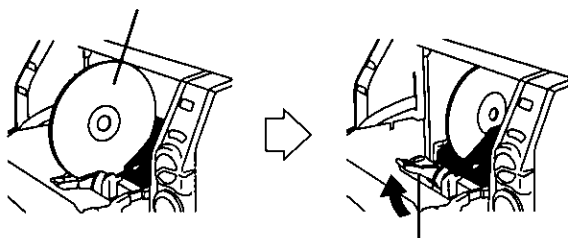

Raise the lever.

4. Close the rack panel gently.

You will hear a catching sound when the rack panel closes.

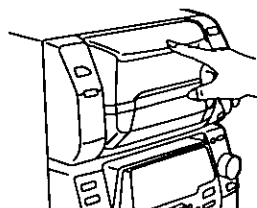

Press on center piece.

How to remove CDs

1. Open the rack panel.
2. Slide the loader carriage to the slot you want.

Note

Do not slide the loader carriage when the lever is down.

3. Lower the end of the lever and then remove CDs.

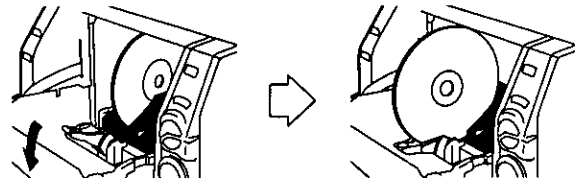

How to know what CD is in what slot

This system comes with a notebook-like binder (liner notes organizer) in which you can keep your CD liners. There are also adhesive numbers for indicating slot numbers in the binder. This is a convenient way to keep track of what CD is in what slot.

Adhesive number (included)

Pocket

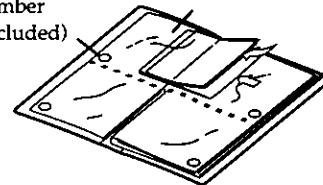

Put two liners back-to-back inside each pocket, as shown above.

Note

Do not put CD cases in the binder.

To prevent damage

Always observe the following points.

- Never load more than one CD in any given slot.
- Do not use 3" (8 cm) CDs fitted with expander rings.
- Do not put anything other than CDs in the changer.
- Do not set a CD in the slot of the CD being played (slot flashes).
- Sometimes the rack panel cannot be opened while a CD is playing. It is a question of time. In such case, wait until you can open it.
- Do not open the rack panel while the changer is changing CDs.
- Do not use cleaning CDs or CDs which are badly warped or cracked.
- Set the system on a flat, level surface. Do not set it on top of magazines, inclined surfaces, etc.
- Always unload all CDs before moving the system.
- Do not use CDs with poorly attached labels or stickers. Adhesive protruding from underneath stickers or left over from peeled off stickers can cause the system to malfunction.
- Do not use irregular shape CDs (heart-shape, octagonal, etc.).



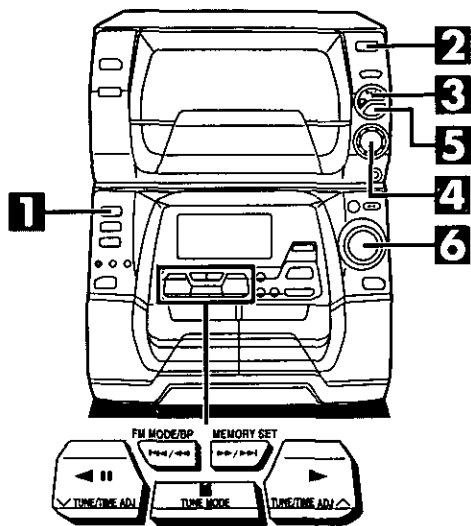

1

2

3

4

5

6

A

Listening to CDs

Normal play

- 1 Press CD.**
The power will come on automatically.
- 2 Set CDs in the rack.**
(For details, see page 12.)
While the changer checks which slots have CDs and which don't, you will hear the internal mechanism working. In the meantime, "SEARCH" will flash on the display.
- 3 Press DISC/TRACK to select the CD selection mode.**
(The indicator illuminates with a green color.)
- 4 Turn JOG to select the desired CD number.**
- 5** While the CD number is flashing (approx. 10 seconds) **Press CD ▶.** (Play will begin.)
The changer will play all CDs up through the one before the CD you started with, and it will stop automatically after playing the last track on it.
- 6 Adjust the volume level.**

To stop the CD play

Press .

To select a disc with the remote control (See page 36.)

- ① Press DISC.
- ② while "—" flashing (approx. 10 seconds)
Press the numeric button(s) to select the desired CD.

To select a two-digit CD

Press ≥ 10 and then the two numbers you want within 10 seconds or so.

For example

CD no. 20: $\geq 10 \rightarrow 2 \rightarrow 0$

CD no. 35: $\geq 10 \rightarrow 3 \rightarrow 5$

When "➤" appears on the display

It indicates there are 13 or more tracks on the CD at the playing position.

To pause	Press during playback. To resume playback, press .
To search forward/backward (Search)	Hold down (backward) or (forward) during playback.
To skip forward/backward	Press (backward) or (forward) during playback.

Note

- If you leave the front panel open while a CD is in play, when the CD is over, the changer will stop.
- During random play (page 15), you cannot skip to tracks which have already been played.
- During program play (page 16) or random play, you cannot search forward or backward over tracks.
- During program play, skipping is always in the programmed order, whether forward or backward.

One-touch play

When the system is OFF, playing starts automatically when you press CD.

For your reference

In step 5, you can also begin playback by pressing the basic operating button .

Listening to CDs

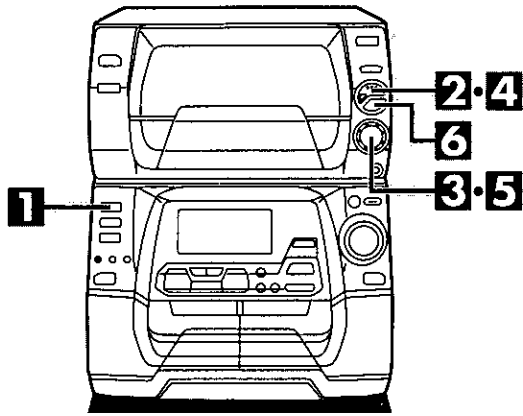

Direct access play

You can listen to a particular track on a particular CD.

- 1 Press CD.**
- 2 Press DISC/TRACK to select the CD selection mode.**
(The indicator illuminates with a green color.)
- 3 Turn JOG to select the desired CD number.**
- 4 While the CD number is flashing (approx. 10 seconds) Press DISC/TRACK to select the track selection mode.**
(The indicator illuminates with a red color.)
- 5 While the track number is flashing (approx. 10 seconds) Turn JOG to select the desired track number.**
- 6 While the track number is flashing (approx. 10 seconds) Press CD ►.**
The CD will be played from the selected track.

To stop the CD play

Press ■.

To select a disc/track with the remote control (See page 36.)

- ① Press DISC.
- ② While "—" is flashing (approx. 10 seconds) Press the numeric button(s) to select the desired CD.
- ③ Press the numeric button(s) to select the track.

To select a two-digit track

Press ≥ 10 and then the two numbers you want within 10 seconds or so.

For example

Track no. 20: $\geq 10 \rightarrow 2 \rightarrow 0$

Track no. 35: $\geq 10 \rightarrow 3 \rightarrow 5$

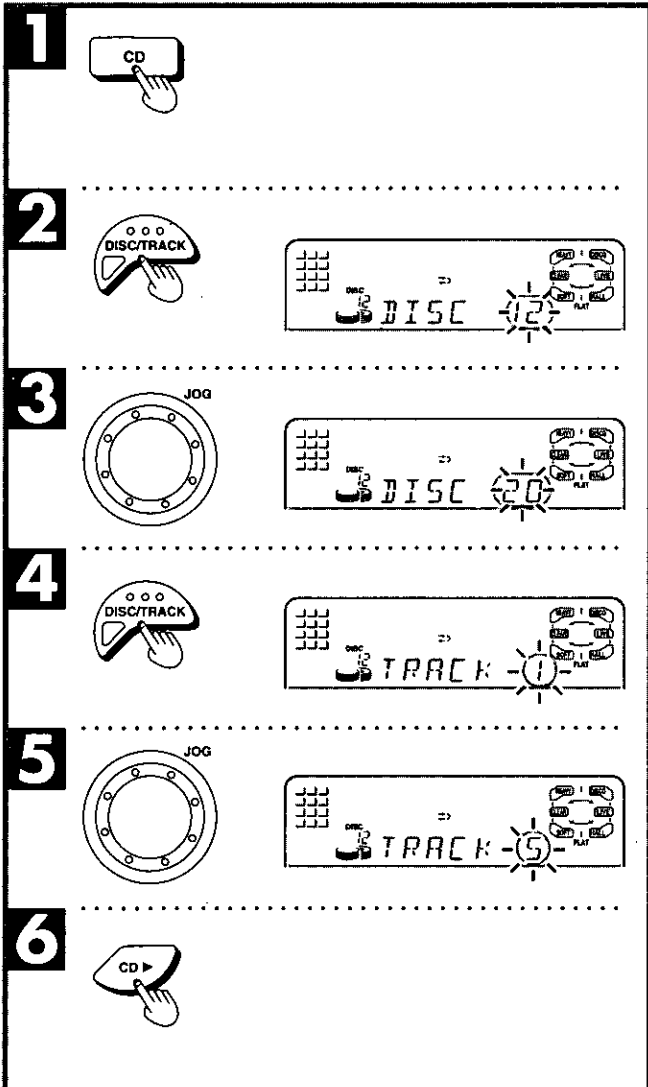

Listening to CDs

Single CD play

A

Single CD play is for that special CD of yours, perhaps one you just bought. You see, the changer has a slot for one special CD which you can use even when the rack is full (max. 50 CDs).

1 Press **OPEN** to open the rack panel, and set the CD in the slot No. 0.

2 Close the rack panel and press **SINGLE ▶**.
The CD in the slot No. 0 will be played from the first track to the last.

For your reference

While "SINGLE" appears on the display, you can start play from the ▶ button as well as the SINGLE ▶ button.

Repeat play

B

by remote control only

Press **REPEAT** before or during play.

All tracks on the loaded CD are repeated.

To cancel repeat play

Press **REPEAT** once again.

To repeat a favorite track

1. Program the track you want (page 16).
2. Press **REPEAT** and make sure "↺" is displayed.
3. Press ▶. Playback will start.

To repeat just one track

Set the 1-TRACK mode (page 18), press **REPEAT** before or during playback, and make sure "↺" is displayed.

To repeat all tracks on a specific CD

Set the 1-DISC mode (page 19), press **REPEAT** before or during playback, and make sure "↺" is displayed.

Random play

C

by remote control only

Press **RANDOM**.

All tracks on the loaded CDs will be played in random order. Playback will stop automatically when the maximum of 72 tracks from the loaded CDs have been played.

To cancel random play

Press **RANDOM** once again.

For random play with just one specific CD

Set the 1-DISC mode (page 19) and press **RANDOM**.

Note

- You can use random play with your program. Only the programmed tracks will be played, but in random order.
- Once more than 25 tracks have been played in random mode, the same track may be played twice.

A

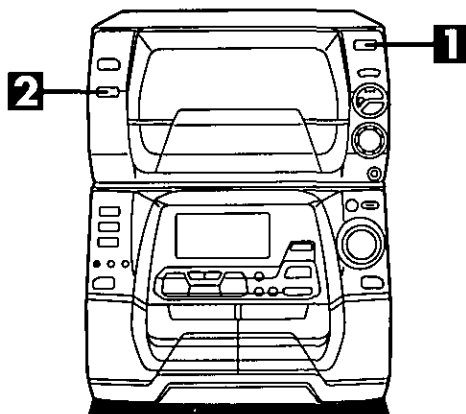

1

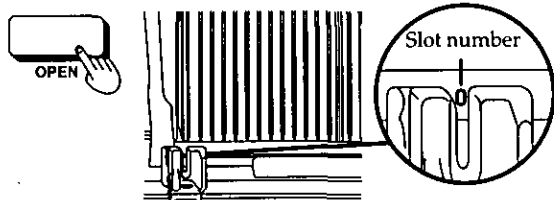

2

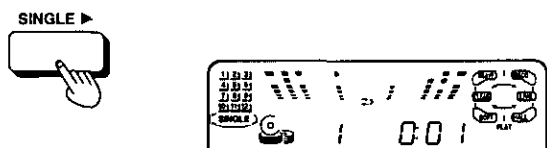

B

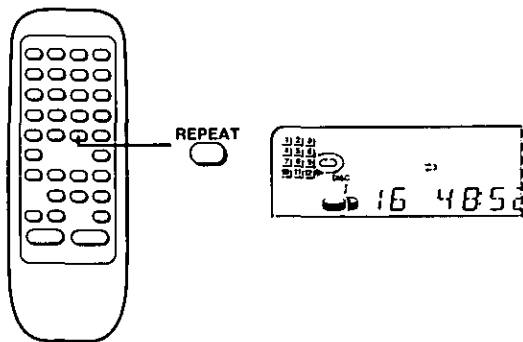

C

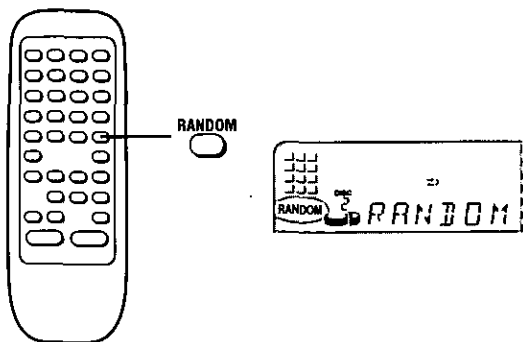

Listening to CDs

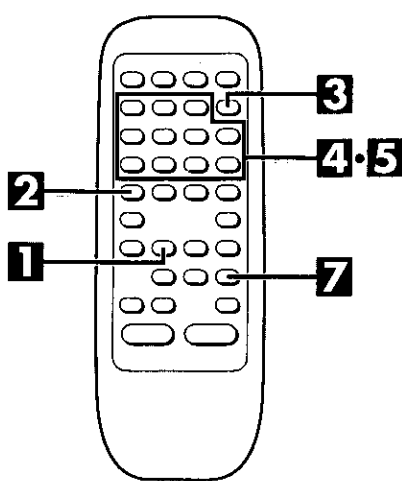

Program play

by remote control only

- Everyone has his/her favorite tracks. You can program the changer to play them in a specific order. With this changer, you can make one program and fill it with up to 24 selections from any of the CDs in the rack.
- You can also program a certain track during playback. (See "Direct programming" below.)

1 Press CD.

2 [In the stop mode]
Press PROGRAM.

3 Press DISC.

4 While "--" is flashing (approx. 10 seconds)
Select the CD(s) you want with the numeric buttons.

You can select slot No. 0.
"SINGLE" appears on the display.

5 Press the numeric button(s) to select the desired track.

6 Repeat steps 3 through 5 until you have programmed all the tracks you want.

7 Press ►.
Play will start in the programmed sequence.

Direct programming

If, while listening to a certain track, you decide that you want to program that track to your program, you can with direct programming.

[While the track you want to program is playing]

Press DIRECT PRGM.

The display will return to the original indication after about 3 seconds.

When you make a program as explained under "Program play" above, and then perform this procedure without clearing the program first, the selected track is added to the end of the program.

To listen to programmed tracks, press PROGRAM and check "PRGM" appears on the display, then press ►.

Note

During program play, the DIRECT PRGM button does not operate.

(Continued on next page)

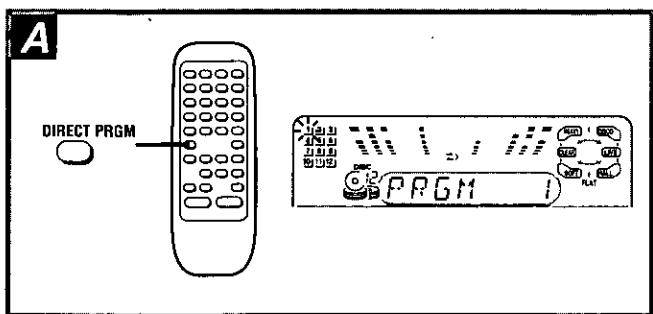
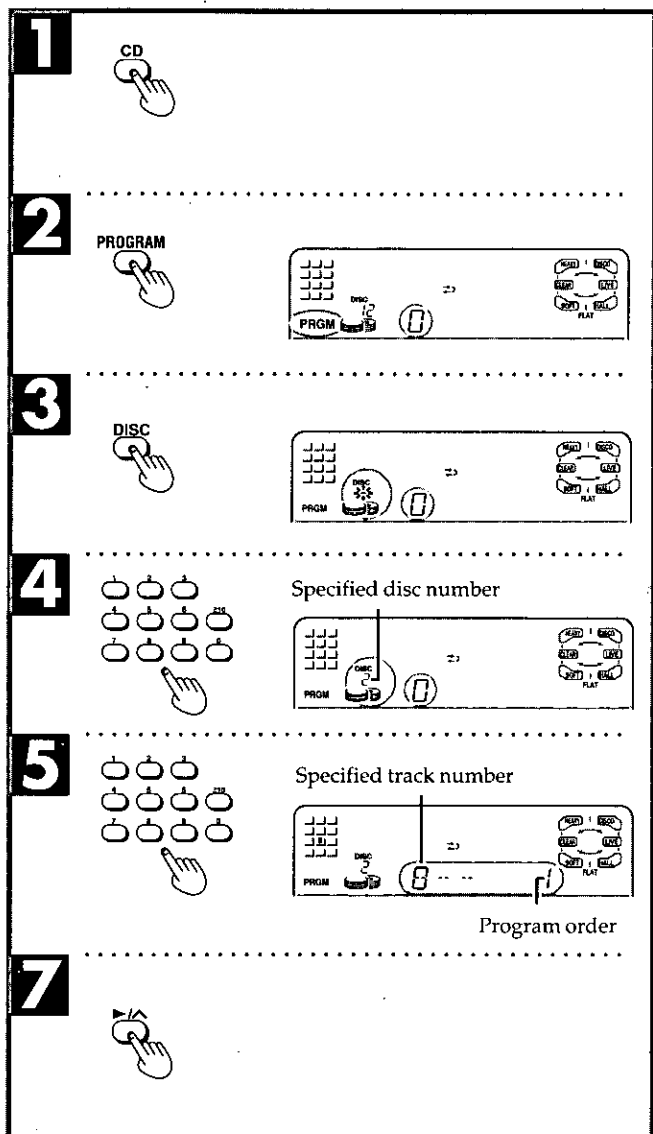

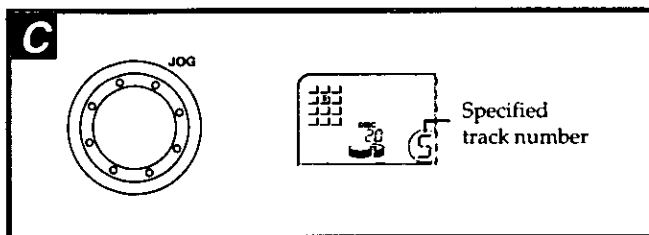
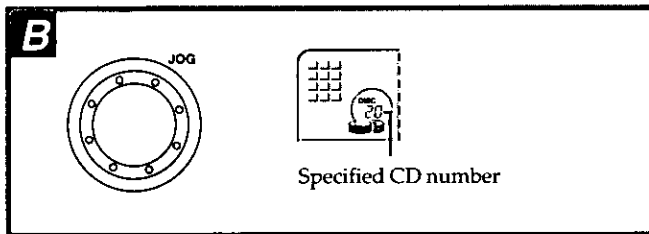
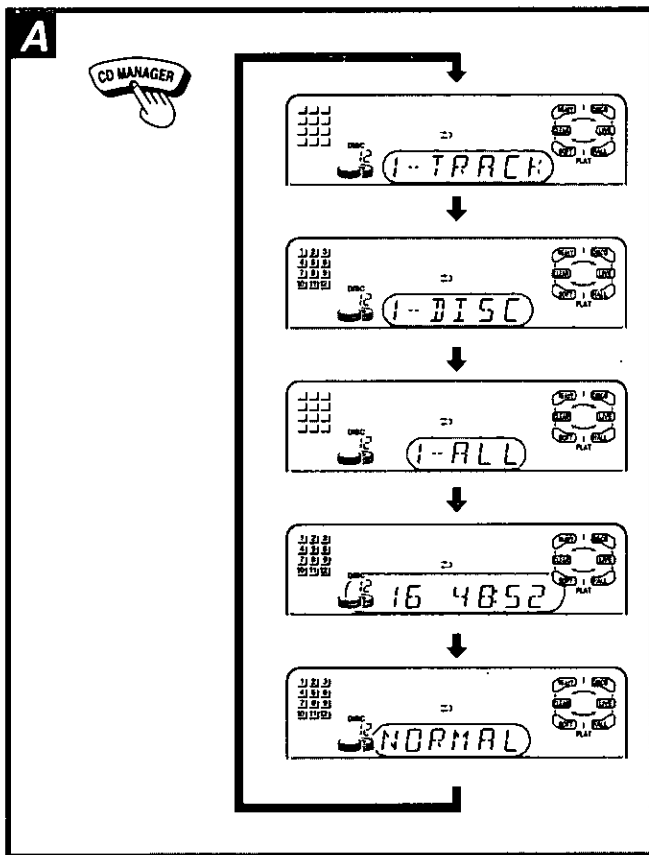
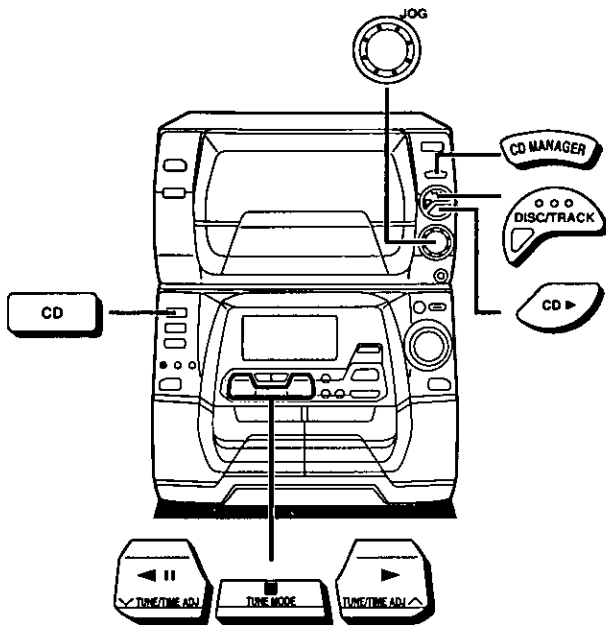

Listening to CDs

To listen to special CDs and tracks (CD MANAGER function)

This function makes it easier for you to select special CDs and tracks from amongst those loaded in the changer.

You can use this function to make recordings as well.

There are 3 CD/track selection modes.

- For playing back 1 track on 1 CD only from all loaded CDs
1-Track mode (1-TRACK)

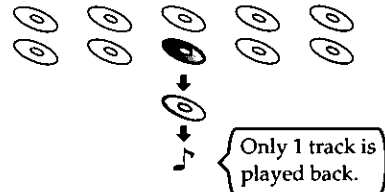

- For playing back 1 CD only from all loaded CDs
1-Disc mode (1-DISC)

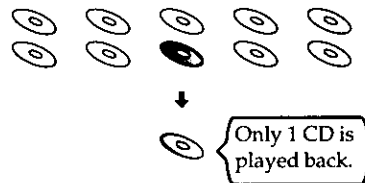

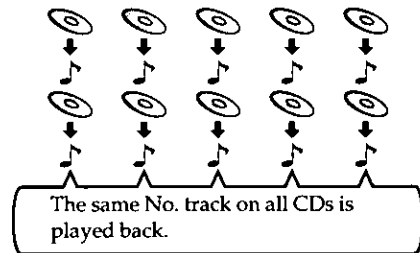

- For playing back the same numbered track (1 track) on all loaded CDs
1-Track All-Disc mode (1-ALL)



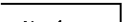

To listen to 1 track only (1-TRACK)

- 1 Press CD.**
- 2 Press CD MANAGER to select "1-TRACK".** Every time you press the button;
1-TRACK → 1-DISC → 1-ALL → → NORMAL ← Previous display ← (OFF)
- 3 Press DISC/TRACK to select the CD selection mode.**
(The indicator illuminates with a green color.)
- 4 Turn JOG to select the desired CD number.**
- 5 Press DISC/TRACK to select the track selection mode.**
(The indicator illuminates with a red color.)
- 6 Turn JOG to select the desired track number.**
- 7 Press CD ►.**
The selected track will start.

To listen to 1 CD only (1-DISC)

- 1 Press CD.**
- 2 Press CD MANAGER to select "1-DISC".** 
Every time you press the button;
1-TRACK→1-DISC→1-ALL 
↑NORMAL←Previous display←
(OFF)
- 3 Press DISC/TRACK to select the CD selection mode.**
(The indicator illuminates with a green color.)
- 4 Turn JOG to select the desired CD number.** 
- 5 Press CD ►.**
The selected CD will be played from the first track to the last.

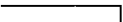
To listen to the same numbered track on all CDs (1-ALL)

- 1 Press CD.**
- 2 Press CD MANAGER to select "1-ALL".** 
Every time you press the button;
1-TRACK→1-DISC→1-ALL 
↑NORMAL←Previous display←
(OFF)
- 3 Press DISC/TRACK to select the track selection mode.**
(The indicator illuminates with a red color.)
- 4 Turn JOG to select the desired track number.** 
- 5 Press CD ►.**
The same numbered track on all loaded CDs will be played in order.

When playback ends

"NORMAL" will appear on the display for about 3 seconds, then the CD MANAGER function will turn OFF automatically.



To stop play

Press ■.



When you select the wrong CD or track

●1-TRACK mode



To reselect a track on the same CD

Follow steps  and .



To reselect a track on another CD

Follow steps -.

●1-DISC mode

Reselect a CD with steps  and .

●1-ALL mode

Reselect the track with steps  and .

Note

- You can use the repeat function (page 15) and random play (page 15) at the same time. However, you can only select the repeat function in 1-TRACK mode.
- During 1-ALL mode, you cannot skip to a CD which has already finished.
- During 1-ALL mode, if the selected track is not found on a certain CD, the changer automatically skips that CD and continues playing from the next CD.

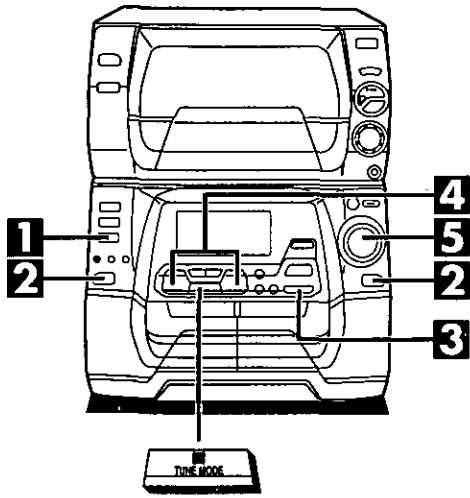

1 TAPE DECK 1/2

2 DECK 1 OPEN DECK 2 OPEN
Front side

3 REV MODE

4 Tape direction

5 VOLUME
DOWN UP

A Deck in use

Listening to tapes

Type of tape which can be played correctly

The system automatically identifies the type of tape.

NORMAL POSITION / TYPE I	○
HIGH POSITION / TYPE II	○
METAL POSITION / TYPE IV	○

You can use either deck 1 or deck 2 for tape playback.

- 1 Press TAPE DECK 1/2.**
The power will come on automatically.
- 2 Press DECK 1 ▲ OPEN or DECK 2 ▲ OPEN, and then insert the tape.**
Insert the tape with the exposed tape facing down.
Close the holder by hand.
- 3 Press REV MODE to select the reverse mode.**
Every time you press the button;
 - : One side is played, then playback stops automatically.
 - : Both sides (front side → reverse side) are played one time each, then playback stops automatically.
 - : Both sides are played 8 times each, then playback stops automatically.
- 4 Press ◀ or ▶ to start playback.**
▶: The forward side (front side) will play.
◀: The reverse side will play.
- 5 Adjust the volume level.**

To stop tape playback

Press ■.

To change the deck to be used

Press TAPE DECK 1/2 to select the deck you want to use when you load cassettes into both decks.

To listen to 2 tapes consecutively

Load a tape into each deck and select . Both tapes will be played 8 times each.

Note

Playback is momentarily interrupted while playing back tapes, if you open the other deck.

One-touch play

When the system is OFF, playing starts automatically when you press TAPE DECK 1/2.

Before recording (Deck 2 only)

To fast-forward or rewind the tape

Press **◀◀/◀◀** or **▶▶/▶▶** in the stop mode.

Tape direction	To rewind	To fast-forward
"▶"	◀◀/◀◀	▶▶/▶▶
"◀"	▶▶/▶▶	◀◀/◀◀

To find the beginning of a program (TPS: Tape Program Sensor)

Press **◀◀/◀◀** or **▶▶/▶▶** during play.

Tape direction	To play the current tune from the beginning	To play the next tune from the beginning
"▶"	◀◀/◀◀	▶▶/▶▶
"◀"	▶▶/▶▶	◀◀/◀◀

Note

The TPS function searches for silent parts of about 4 seconds in length which are normally found between tunes. As a result, it may not function properly in the following cases.

- With short silent parts
- When noise occurs between tunes
- With silent parts found within tunes

Type of tape which can be recorded correctly

The system automatically identifies the type of tape.

NORMAL POSITION/TYPE I	○
HIGH POSITION/TYPE II	○
METAL POSITION/TYPE IV	×

This system cannot correctly make a recording or erasing, if metal position tapes are used.

To record from the beginning of the tape

You cannot record on the leader part of the tape. Before recording, wind the tape past the leader to a point where recording can start immediately.

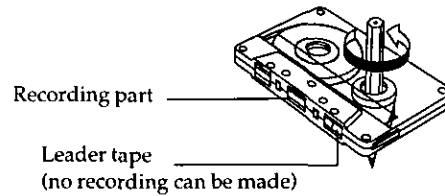

How volume, sound quality/field, super woofer and V. BASS effect recording

The tape you are recording is not affected whatsoever by changes in volume, sound quality/field, super woofer (SC-AK90/SC-AK91) or V. BASS (SC-AK70/SC-AK71).

- In recording, sound quality/field are set automatically to "FLAT".
- You can change volume, super woofer and V. BASS effect for the playback sound.

To erase a recorded sound

1. Press TAPE DECK 1/2.
2. Insert the recorded tape into deck 2.
3. Press REV MODE to select reverse mode.
4. Press ● REC/STOP.

Note

- You cannot open the deck 1 while recording.
- You cannot fast-forward or rewind one deck while recording with the other.

Recording from radio broadcasts

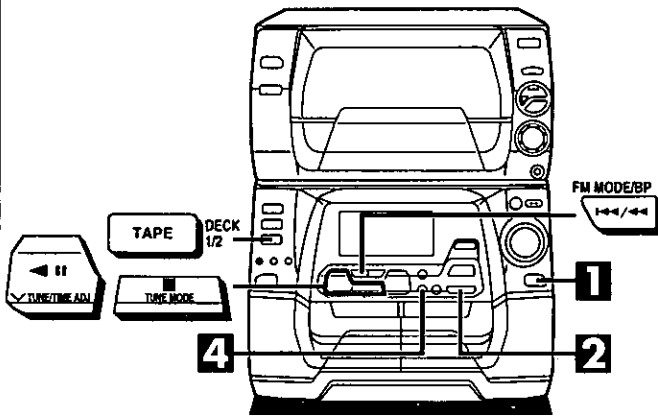

1 Press DECK 2 \blacktriangle OPEN, and then insert the tape.

Close the holder by hand.

Tape direction is automatically set to "▶".

2 Press REV MODE to select the reverse mode.

Every time you press the button;

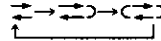

▶: One side is recorded, then recording stops automatically.

▶▶, ◀◀: Both sides (front side → reverse side) are recorded, then recording stops automatically.

3 Select a radio station. Perform steps 1 through 3 on page 11.

4 Press \bullet REC/STOP to start recording.

If you selected ◀◀ in step 2, the direction will automatically change to ▶▶ when recording starts.

To stop recording

Press \bullet REC/STOP again.

Recording can also be stopped by pressing \blacksquare .

To start recording on reverse side

Load a tape and change the tape direction as explained here below.

1. Press TAPE DECK 1/2 and select tape deck 2.
2. Press \blacktriangleleft and immediately thereafter \blacksquare . The tape direction will be shown as " \blacktriangleleft ".

To record from a specific point on a tape

Before recording, advance the tape to the point from where you want to start recording.

To cut an unnecessary part while recording

1. Press \bullet REC/STOP when hearing an unnecessary part. The cassette deck will go into the stop mode.
2. Press \bullet REC/STOP to resume recording. Recording will continue in the same direction as before.

Note

When recording an AM broadcast, volume is momentarily interrupted when you start and stop the recording.

To reduce the noise while recording an AM broadcast (Beat proof function) \square

Press FM MODE/BP while recording.

Each time you press the button, BP 1 and BP 2 will be displayed alternately.

Select the position where there is less noise.

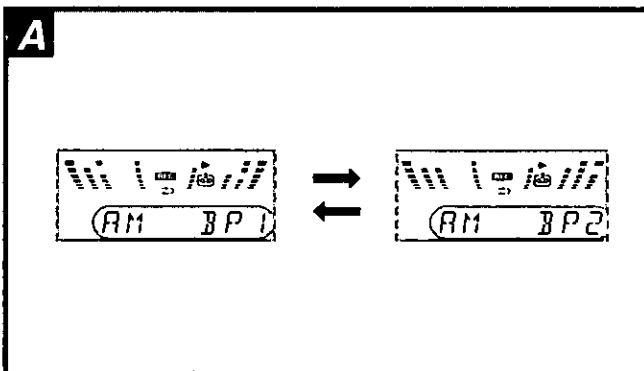
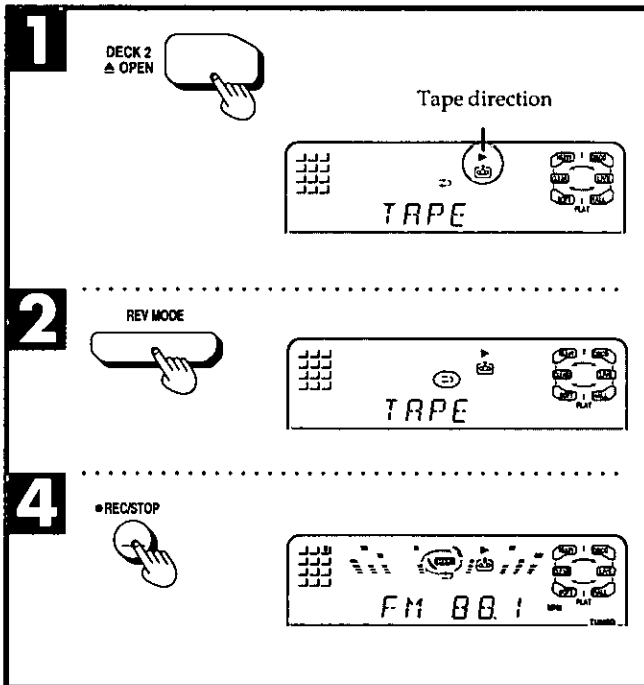

Recording from CDs

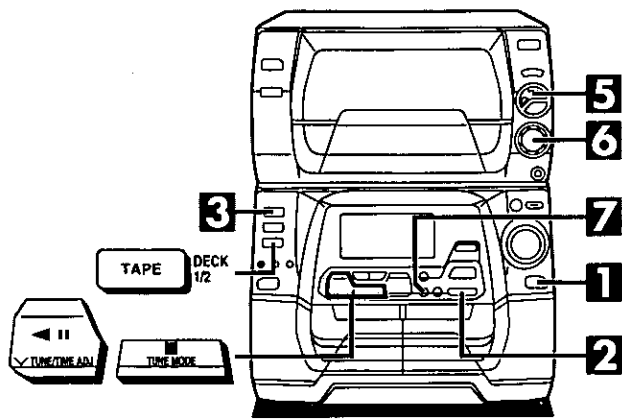

- 1 Press **DECK 2 ▲ OPEN**, and then insert the tape.

Close the holder by hand.

Tape direction is automatically set to "▶".

- 2 Press **REV MODE** to select the reverse mode.

Every time you press the button;

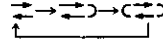

⇄: One side is recorded, then recording stops automatically.

→, ⇄: Both sides (front side→reverse side) are recorded, then recording stops automatically.

- 3 Press **CD**.

- 4 Set **CDs in the rack**.

(See page 12.)

- 5 Press **DISC/TRACK** to select the CD selection mode.

(The indicator illuminates with a green color.)

- 6 Turn **JOG** to select the desired CD number.

- 7 While the CD number is flashing (approx. 10 seconds)

Press **● REC/STOP** to start recording

- If you selected ⇄ in step 2, the direction will automatically change to → when recording starts.

- The recording will proceed from the first track on the selected CD.

To stop recording

- To add a 4 second silent interval before stopping.

Press **■**. The CD will stop automatically too.

- To stop recording without a silent interval

Press **● REC/STOP**. The CD will stop automatically too.

To record on reverse side

Before recording, load a tape and change the tape direction as explained here below.

1. Press **TAPE DECK 1/2** and select tape deck 2.

2. Press **◀** and immediately thereafter **■**. The tape direction will be shown as "◀".

To record from a specific point on a tape

Before recording, advance the tape to the point from where you want to start recording.

To record programmed tracks

1. After step 4, program the track you want (performs steps 2–6 on page 16).

2. Press **● REC/STOP** to start recording.

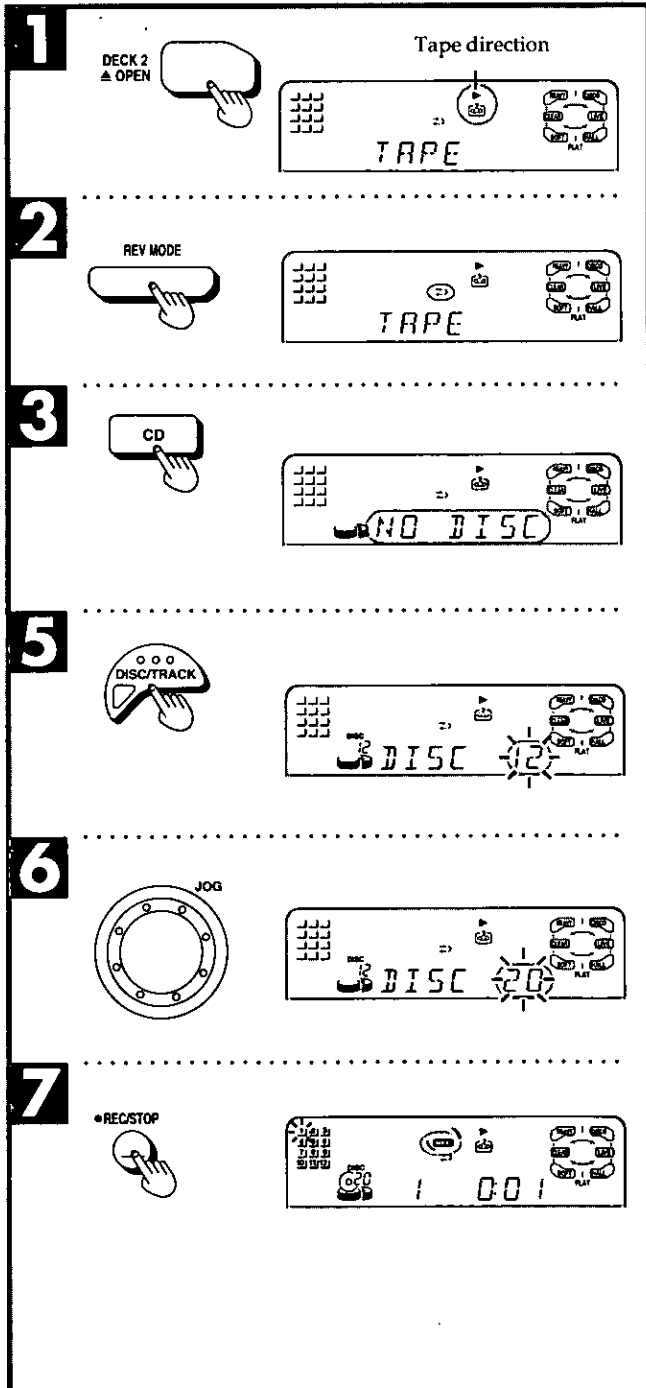

Recording from CDs

To record special CDs and tracks (CD MANAGER function)

This function makes it easier for you to select special CDs and tracks from amongst those loaded in the changer.

- While recording, if a track is cut off in the middle at the end of the front side, it is re-recorded from the beginning, on the reverse side.

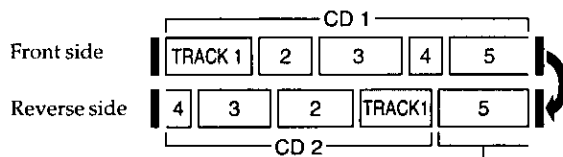

The interrupted track is re-recorded in its entirety on the reverse side.

- Recording is interrupted definitively at the end of the reverse side.

Before recording



Prepare the tape you want to use. Performs steps 1 and 2 on page 23.

To record 1 track only (1-TRACK)

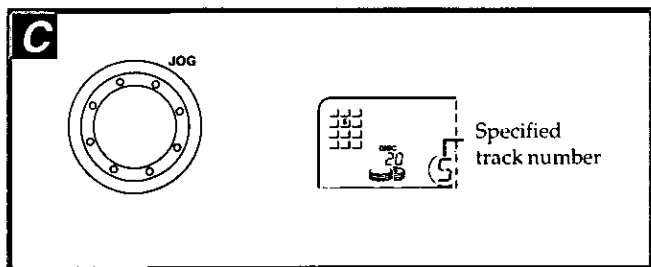
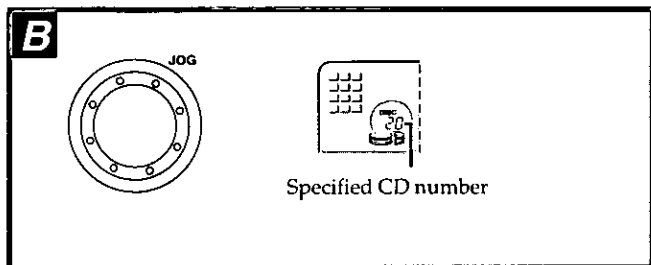
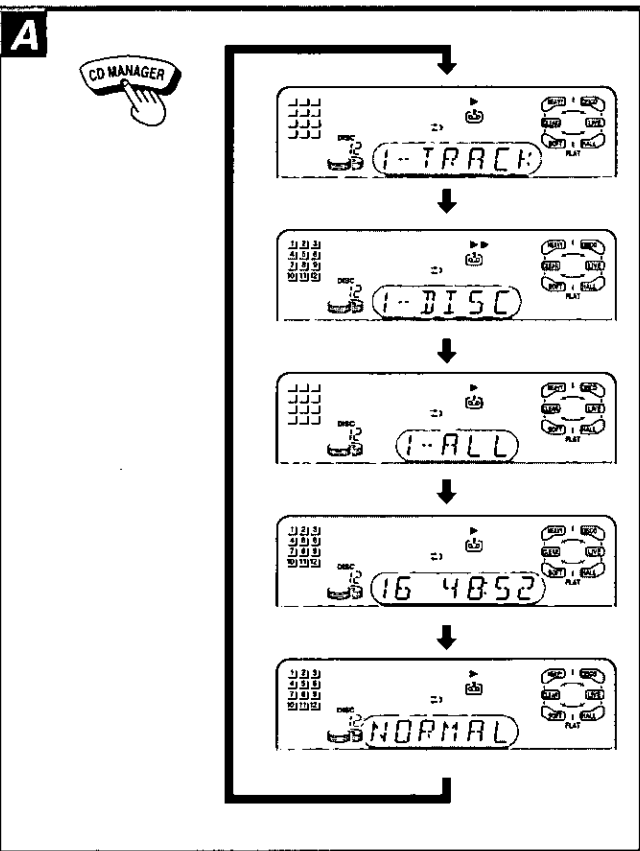
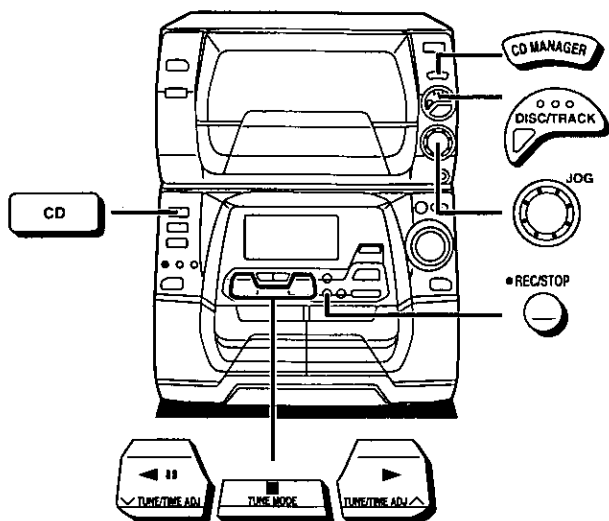

- 1 Press CD.**
- 2 Press CD MANAGER to select "1-TRACK".** Every time you press the button;
1-TRACK → 1-DISC → 1-ALL →
↑ NORMAL ← Previous display ←
(OFF)
- 3 Press DISC/TRACK to select the CD selection mode.**
(The indicator illuminates with a green color.)
- 4 Turn JOG to select the desired CD number.**
- 5 Press DISC/TRACK to select the track selection mode.**
(The indicator illuminates with a red color.)
- 6 Turn JOG to select the desired track number.**
- 7 Press ● REC/STOP.**
The selected track will be recorded.

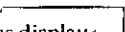

To record 1 CD only (1-DISC)

- 1 Press CD.**
- 2 Press CD MANAGER to select "1-DISC".** 
Every time you press the button;
1-TRACK→1-DISC→1-ALL—
↑NORMAL←Previous display←
(OFF)
- 3 Press DISC/TRACK to select the CD selection mode.**
(The indicator illuminates with a green color.)
- 4 Turn JOG to select the desired CD number.** 
- 5 Press ● REC/STOP.**
The selected CD will be recorded.

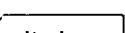
To record the same numbered track on all CDs (1-ALL)

- 1 Press CD.**
- 2 Press CD MANAGER to select "1-ALL".** 
Every time you press the button;
1-TRACK→1-DISC→1-ALL—
↑NORMAL←Previous display←
(OFF)
- 3 Press DISC/TRACK to select the track selection mode.**
(The indicator illuminates with a red color.)
- 4 Turn JOG to select the desired track number.** 
- 5 Press ● REC/STOP.**
The same numbered track on all loaded CDs will be recorded in order.

When recording ends

"NORMAL" will appear on the display for about 3 seconds, then the CD MANAGER function will turn OFF automatically.

To stop recording

- To add a 4 second silent interval before stopping
Press ■. The CD will automatically stop too.
- To stop recording without a silent interval
Press ● REC/STOP. The CD will stop automatically too.

When you select the wrong CD or track

The same reselection procedure is used with all three modes. Perform this procedure before recording starts.

To reselect a CD

1. Press DISC/TRACK to select the CD selection mode.
2. Turn JOG to select the desired CD number.

To reselect a track

1. Press DISC/TRACK to select the track selection mode.
2. Turn JOG to select the desired track number.

For your reference

During 1-ALL recording mode, if the selected track is not found on a certain CD, the changer automatically skips that CD and continues recording from the next CD.

Tape-to-tape recording

The recording level will be recorded as they are on the tape being played back.

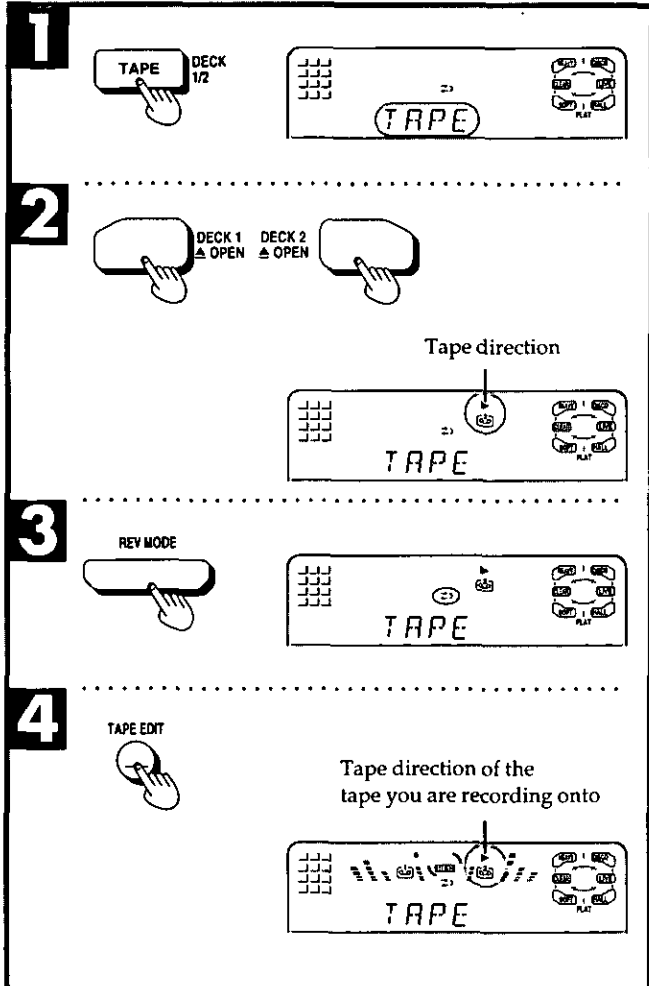
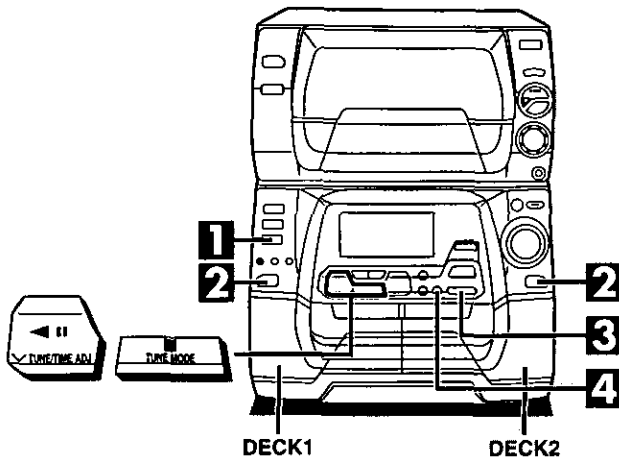

1 Press TAPE DECK 1/2.

2 Press \blacktriangle OPEN on both decks, and then insert the tapes.

For playback: Into deck 1

For recording: Into deck 2

Close each deck's holder by hand.

Tape direction is automatically set to "▶".

3 Press REV MODE to select the reverse mode.

Every time you press the button;

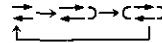

▶: One side is recorded, then recording stops automatically.

↔, ↔: Both sides (front side→reverse side) are recorded, then recording stops automatically.

4 Press TAPE EDIT to start recording.

• If you selected ↔ in step 3, the direction will automatically change to ▶ when recording starts.

To stop recording

Press ■.

Both decks will stop.

To record on side B

Before recording, load a tape and change the tape direction as explained here below.

1. Press TAPE DECK 1/2 and select tape deck 2.

2. Press ◀ and immediately thereafter ■. The tape direction will be shown as "◀".

To record from a specific point on a tape

Before recording, advance the tape to the point from where you want to start recording.

Sound quality, field, etc.

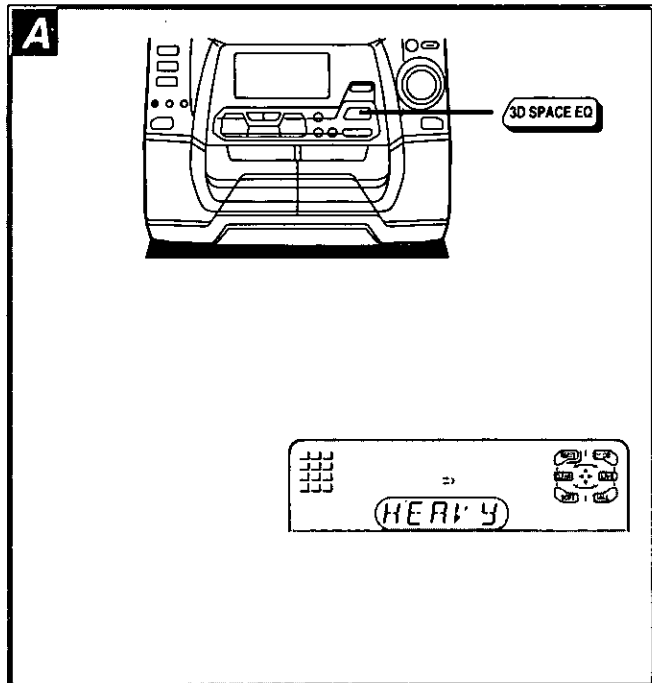

Selecting sound quality and field **A**

Base your selection on the type of music and how you want to listen to it.

Press 3D SPACE EQ to select sound quality and field.

Each time you press the button;

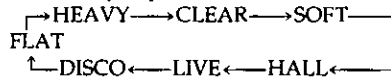

HEAVY: Use to add "punch" to rock and other music.

CLEAR: Use to clarify the treble range of jazz, etc.

SOFT: Use to listen to background music, etc.

HALL: Use to impart a deep bass and spread which will make you feel as if you were in a large concert hall.

LIVE: Use primarily for vocal pieces to add gloss to the vocals.

DISCO: Use to reproduce a long reverberating sound like that heard in discotheques.

Note

In recording, the sound quality/field will set automatically to "FLAT".

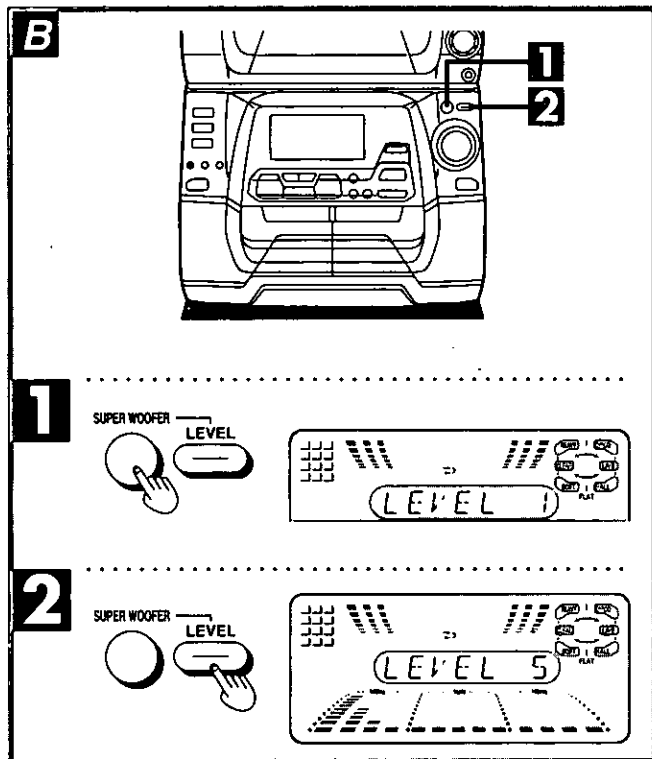

To cancel the mode

Press 3D SPACE EQ and check "FLAT" lights up.

To boost bass **B**

SC-AK90/SC-AK91 only

You can adjust bass below 120 Hz to 5 different levels.

1 Press SUPER WOOFER.

(The button lights up.)

2 Press LEVEL to select the desired level.

Each time you press the button, the level indication will change consecutively from "LEVEL 1" through to "LEVEL 5".

To cancel the mode

Press SUPER WOOFER again.

Adding bass **C**

SC-AK70/SC-AK71 only

Press V. BASS.

Press the button again to cancel.

"V. BASS" goes out.

Note

You cannot record V. BASS effect, but you can use it for playback sound.

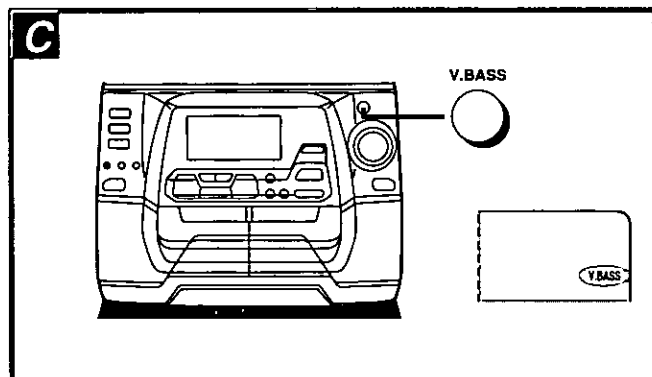

Singing along with KARAOKE

SC-AK91/SC-AK71 only

This unit lets you enjoy the KARAOKE fun with audio CDs and audio tapes.

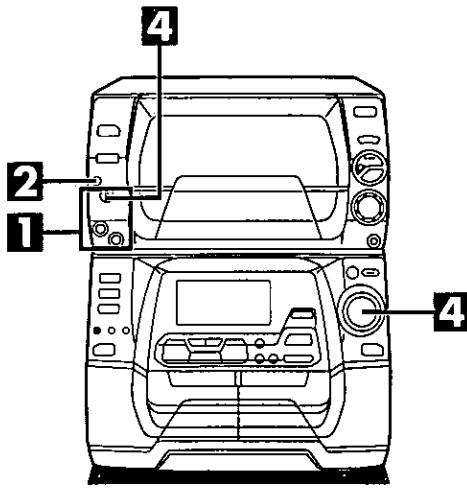

1 First, lower volume with MIC VOL, then, connect the microphone to the MIC 1 and/or MIC 2 jacks.

Plug type: 3,5 mm (1/8 in.) monaural

2 Press KARAOKE to select the voice mode.

Every time you press the button;
 V•MUTE→MONO•L→MONO•R
 (OFF)

Voice mode selection

If you want to play with the KARAOKE function, check first whether or not your software is formatted for KARAOKE and then select the voice mode as indicated below.

○: Appropriate

●: For practice, etc.

Software Voice modes	KARAOKE		Non-KARAOKE
	Sound multiplex	Stereo	
(OFF)	● (Background music+ Voice)	○	● (For singing along)
V•MUTE	—	—	○
MONO•L	○ (Background music)	—	—
MONO•R	● (Voice)	—	—

Note

A bar is indicated in the above table when the voice mode is least effective. It is better to avoid using the mode in such cases.

V-MUTE function

The voice portion of the track is blocked out but not the background music.

You need software recorded in stereo sound if wanting to use the voice mute function. Voice and/or static may be reproduced with the following types of software.

- Software recorded monaural
- Classic music, or works performed by a limited number of instruments
- Chorus works or duets

3 Start the source (CD, etc.).

4 Adjust volume with VOLUME and MIC VOL and sing along.

To cancel the KARAOKE

Press KARAOKE to select "(OFF)" mode.

Note

- If a strange noise (squealing or howling) is emitted during use, move the microphone far away from the speakers, or turn down the microphone volume.
- When you are not using the microphone, disconnect it from the MIC jack, and turn down the microphone volume level to MIN.
- Sound field cannot be used with KARAOKE nor can the radio.

1 MIC VOL → MIC1 MIC2

2 KARAOKE

4 VOLUME MIC VOL

Singing along with KARAOKE

To record your "KARAOKE" performance

- 1 First, lower volume with MIC VOL then, connect the microphone to MIC 1 and/or MIC 2 jacks.
- 2 Press DECK 2 \blacktriangle OPEN to insert the tape and then select the reverse mode.
- 3 Press KARAOKE to select the voice mode.
- 4 Start recording and KARAOKE performance.
 - When singing off CDs
Press \bullet REC/STOP and start KARAOKE performance
 - When singing off tapes
Press TAPE EDIT and start KARAOKE performance.

Note

- To playback the recorded tape, be sure to press KARAOKE to select the "(OFF)" mode.
- You cannot record sound field or bass effect with KARAOKE, or radio-backed KARAOKE.

To record your voice

1. First, lower volume with MIC VOL then, connect the microphone to MIC 1 and/or MIC 2 jacks.
2. Press DECK 2 \blacktriangle OPEN to insert a tape and then select the reverse mode.
3. Press TAPE, DECK 1/2.
4. Press \bullet REC/STOP to start recording.
5. Speak through the microphone and adjust volume with VOLUME and MIC VOL.

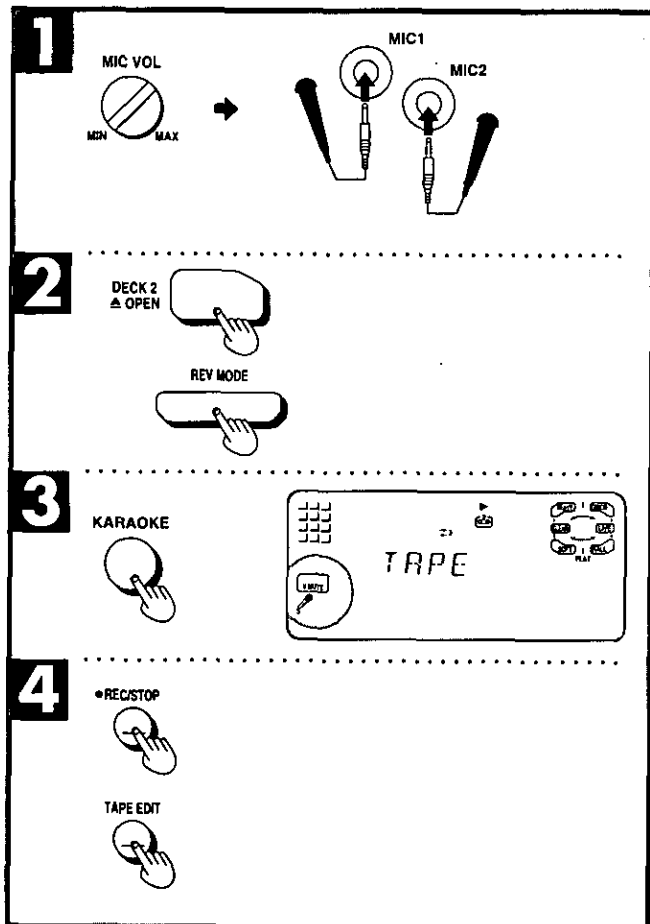
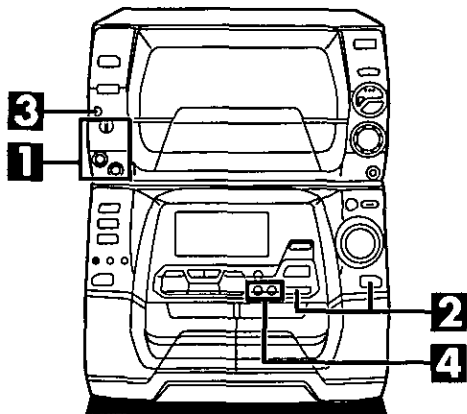

Timers

This system has 3 timers: Play Timer, Record Timer, Sleep Timer.

Play Timer (Ⓞ PLAY)

Select this timer when you want to use the timer as an alarm clock. You can wake up while listening to music (CD, tuner, tape or aux) at a desired volume level and time.



Record Timer (Ⓞ REC)

Select this timer when you want to use the timer to record a midnight program or while you are out.



Sleep Timer (SLEEP)

This timer turns your system OFF at the set time (Max. 2 hours, settable at 30 minute intervals). It lets you fall asleep while listening to music.

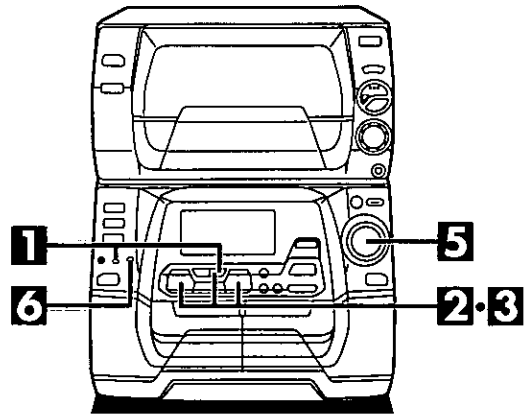
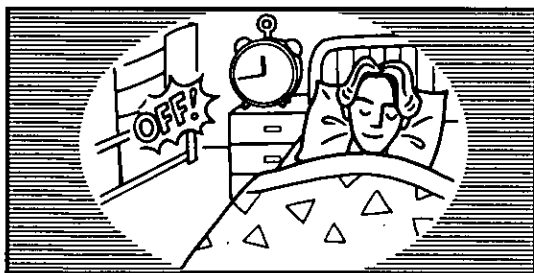

1 ① CLOCK/TIMER

2 ② MEMORY SET

① TUNER/AL TUNER/AL

② MEMORY SET

③ TUNER/AL TUNER/AL

④ MEMORY SET

3 ① TUNER/AL TUNER/AL

② MEMORY SET

③ TUNER/AL TUNER/AL

④ MEMORY SET

5 VOLUME

6 Ⓞ REC/Ⓞ PLAY

↓

Using the play timer

Preparations

- Make sure that you have completed "Setting the time" on page 9.
- Switch on the power.

The figure shows how to set the play timer for playing a CD from 6:30 a.m. to 7:40 a.m.

1 Press CLOCK/TIMER to select "⊙ PLAY".

- ① Every time you press the button;

CLOCK → ⊙ REC → ⊙ PLAY
↑ Previous display ←

- ② (Within 10 seconds or so)

Press MEMORY/SET.

2 "ON" time setting

- ① Press \downarrow or \uparrow to select the starting hour.
- ② Press MEMORY/SET.
- ③ Press \downarrow or \uparrow to select the starting minutes.
- ④ Press MEMORY/SET.

3 "OFF" time setting

- ① Press \downarrow or \uparrow to select the ending hour.
- ② Press MEMORY/SET.
- ③ Press \downarrow or \uparrow to select the ending minutes.
- ④ Press MEMORY/SET.

4 Source selection

Select the desired source and then prepare for playing.

When you play CD(s)

Press CD and insert CD(s).

If more than 1 CD is loaded

- ① Press DISC/TRACK to select the CD selection mode.
(The indicator illuminates with a green color.)
- ② Turn JOG to select the desired CD number.
- ③ Press CD \blacktriangleright and then press \blacksquare .

When you play tape(s)

Press TAPE DECK 1/2 and insert tape(s).

If tapes are loaded in both decks, playback will start from deck 2.

When you play the radio

Press TUNER BAND and tune in the desired station.

When you play a unit connected to the "AUX" terminals

Press AUX.

5 Play volume setting

Set the playback volume.

6 Press ⊙ REC/⊙ PLAY to select "⊙ PLAY".

Every time you press the button;

⊙ REC → ⊙ PLAY

↑ Out (OFF) ←

The system will be turned OFF automatically in a few seconds.

The timer play will start at the preset time with volume increasing gradually up to the volume level you preset.

To switch the timer OFF

Press ⊙ REC/⊙ PLAY and check "⊙ PLAY" goes out.

If you set the timer wrongly

Press ⊙ REC/⊙ PLAY so that "⊙ PLAY" goes out. Then, repeat the procedure from step 1.

To check settings

Press CLOCK/TIMER to select "⊙ PLAY".

Two seconds later, the display will change in the following order.

- ① Play start time
- ② Play over time
- ③ Play source and playback volume

You can check settings even when the system is OFF.

To enjoy the desired source after the timer setting is completed

Even if you change the volume level or music source, the timer play will start with the preset condition.

1. Following step 6, turn ON the power and start playing the desired source.

Note

When you select a CD as the program source

After the CD finishes, if more than 2 CDs are loaded in the changer follow the procedure below.

- ① Press DISC/TRACK to select the CD selection mode.
(The indicator illuminates with a green color.)
- ② Turn JOG to select the desired CD number to start the play.
- ③ Press \blacksquare .

2. Press POWER to standby mode after enjoying the play, and confirm CD(s) or tape(s) has (have) been inserted.

Turning the timer ON/OFF

As long as "⊙ PLAY" is displayed, the play timer will come ON everyday as set.

You can turn the timer ON/OFF by pressing ⊙ REC/⊙ PLAY while the system is OFF.

Remember that when "⊙ PLAY" is displayed, the timer is ON. When not displayed, the timer is OFF.

Note

- If the power is on, the timer will not function. The system must be in the standby mode.
- If you switch the power to the standby mode while the play timer is functioning, the OFF time setting will not be activated.
- If AUX is selected as the source, when the timer comes ON, the system will turn ON and will engage "AUX" as the source. If you want playback from a connected component to start, set the component's timer to the same time. (See the instruction manual that came with the component.)

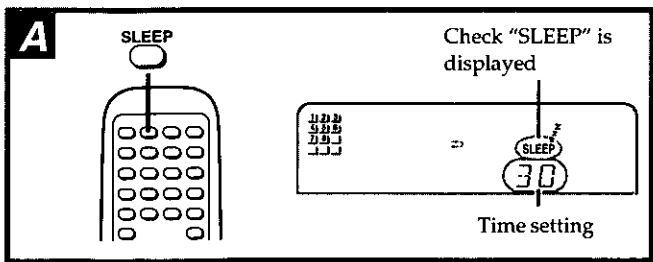
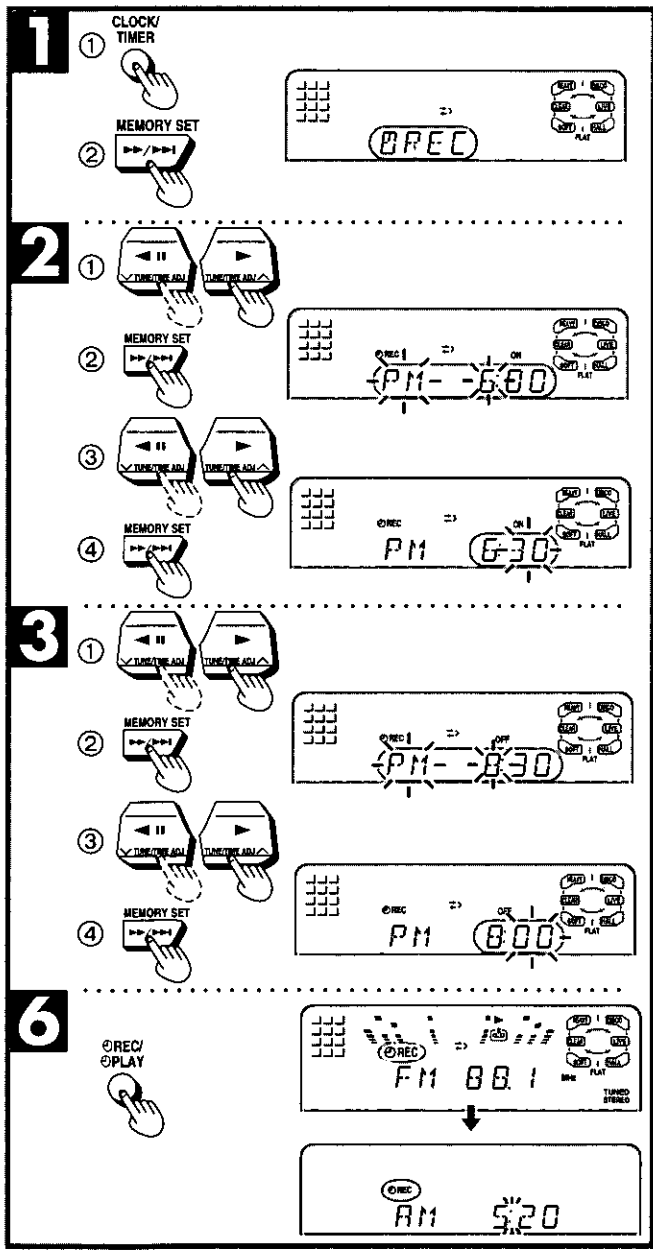
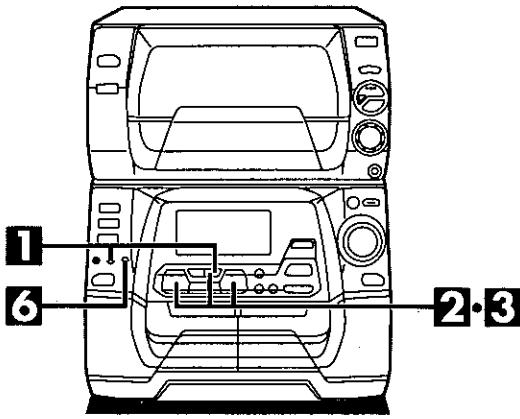

Using the record timer

Preparations

- Make sure that you have completed "Setting the time" on page 9.
- Switch on the power.

Set the timer at least 2 minutes before you want to start recording.

The figure shows how to set the record timer for recording FM broadcasts from 6:30 p.m. to 8:00 p.m.

1 Press CLOCK/TIMER to select "⊙ REC".

- ① Every time you press the button; CLOCK → ⊙ REC → ⊙ PLAY
 ↑ Previous display ↓
- ② (Within 10 seconds or so)
Press MEMORY/SET.

2 "ON" time setting

- ① Press ∨ or ∧ to select the starting hour.
- ② Press MEMORY/SET.
- ③ Press ∨ or ∧ to select the starting minutes.
- ④ Press MEMORY/SET.

3 "OFF" time setting

- ① Press ∨ or ∧ to select the ending hour.
- ② Press MEMORY/SET.
- ③ Press ∨ or ∧ to select the ending minutes.
- ④ Press MEMORY/SET.

4 Source selection

Select the desired source and then prepare for recording.

When you record from the radio

Press TUNER BAND to select "FM" or "AM" and tune in the desired station.

When you record from a unit connected to the "AUX" terminals

Press AUX.

5 Prepare for recording.

1. Insert a tape into deck 2 with the side on which the recording will start facing you.
2. Select the reverse mode.

6 Press ⊙ REC/⊙ PLAY to select "⊙ REC".

- Every time you press the button;
 ⊙ REC → ⊙ PLAY
 ↑ (OFF) ↓

The system will be turned OFF automatically in a few seconds.

About 30 seconds before the set time, the system mutes all sound automatically. Recording will start from front side ("▶").

To switch the timer OFF

Press \odot REC/ \odot PLAY and check " \odot REC" goes out.

If you set the timer wrongly

Press \odot REC/ \odot PLAY so that " \odot REC" goes out. Then, repeat the procedure from step 1.

To check settings

Press CLOCK/TIMER to select " \odot REC".

Two seconds later, the display will change in the following order.

- ① Recording start time
- ② Recording over time
- ③ Recording source

You can check settings even when the system is OFF.

To enjoy the desired source after the timer setting is completed.

Even if you change the music source, the timer recording will start with the preset condition.

1. Following step 6 on page 32, turn ON the power and start playing the desired source.
2. Press POWER to standby mode after you have enjoyed listening to your desired source, and confirm a tape is inserted in deck 2.

Turning the timer ON/OFF

As long as " \odot REC" is displayed, the record timer will come ON everyday as set.

You can turn the timer ON/OFF by pressing " \odot REC/ \odot PLAY" while the system is OFF.

Remember that when " \odot REC" is displayed, the timer is ON. When not displayed, the timer is OFF.

Note

- If the power is ON, the timer will not function. The system must be in the standby mode.
- If you switch the power to the standby mode while the record timer is functioning, the OFF time setting will not be activated.
- If AUX is selected as the source, when the timer comes ON, the system will turn ON, will engage "AUX" as the source and will start recording. If you want to record from a connected component, set the component's timer to the same time. (Refer to your equipment's operating instructions.)

by remote control only

Preparations

Switch on the power.

While enjoying the desired source:

Press SLEEP to select the desired time. \square

Every time you press the button;

\rightarrow 30 \rightarrow 60 \rightarrow 90 \rightarrow 120 \rightarrow OFF \rightarrow

The figure shows how to set the system to standby mode after 30 minutes.

The system is turned off after the set time has elapsed.

To cancel the sleep timer

Press SLEEP to select "OFF".

To confirm the remaining time

(only while power is ON)

Press SLEEP.

To change the time remaining during operation

Press SLEEP to show the remaining time, and then press SLEEP to select the desired time.

Note

The sleep timer turns OFF automatically the moment you attempt to record a CD using CD MANAGER function.

To use two timers together

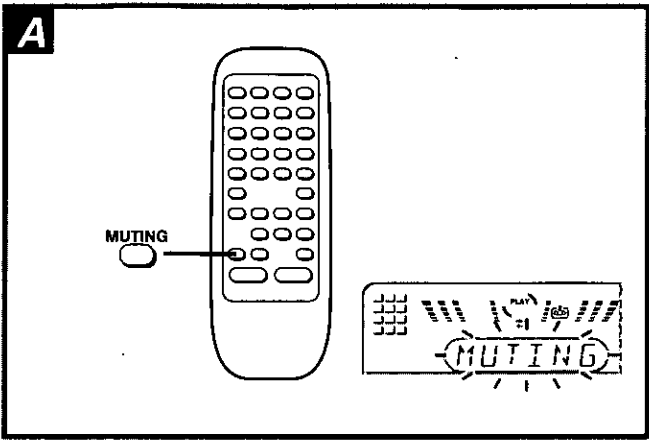

The sleep timer always has priority.
Be sure not to overlap timer settings.

Record timer and sleep timer

To go to sleep listening to a compact disc, and then to make a timer recording from a radio broadcast.

- ① Program the record timer.
Follow steps 1-6 on page 32.
- ② Switch on the power.
- ③ Start CD and set the volume.
- ④ Set the sleep timer (page 33).

Be sure to set the sleep timer to finish before the timer recording begins.

Play timer and sleep timer

To go to sleep listening to an FM broadcast, and wake up the next morning listening to a compact disc.

- ① Program a CD for play timer.
Follow steps 1-6 on page 31.
- ② Switch on the power.
- ③ Tune in the station and set the volume.
- ④ Set the sleep timer (page 33).

For your reference

The play timer cannot be used in combination with the record timer.

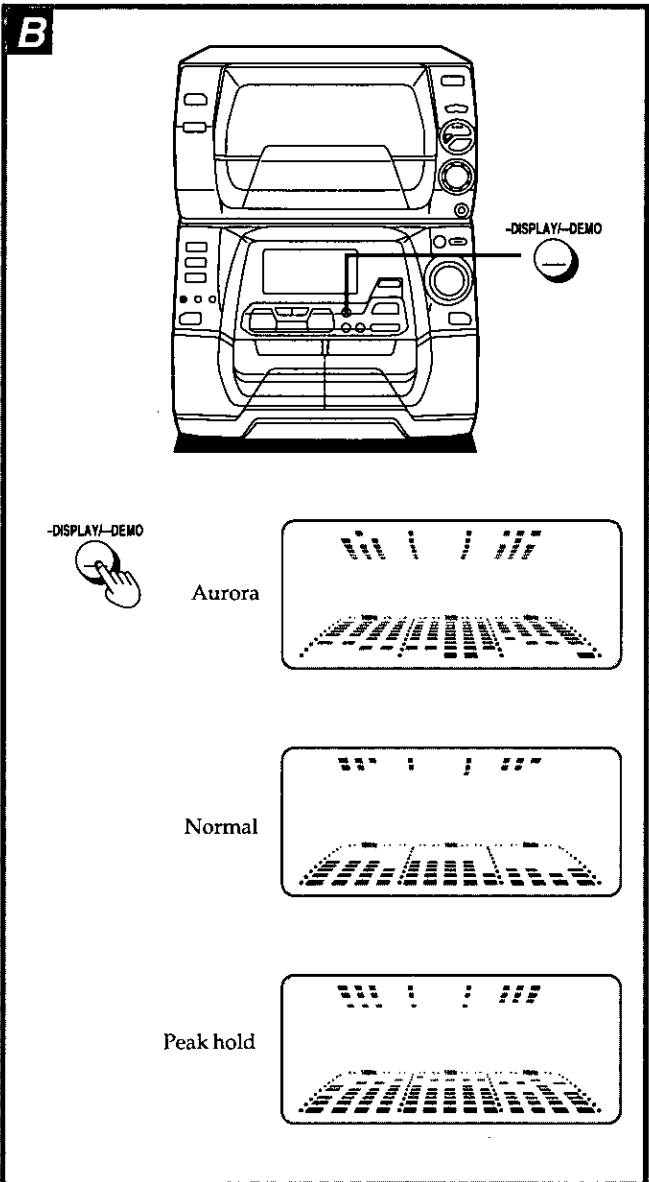

Convenient functions

To mute the volume A

by remote control only

This feature is convenient when you have a telephone call, etc.

Press MUTING.

Press the button again to cancel.

"MUTING" goes out.

Muting can also be cancelled by lowering the volume all the way (-dB).

When the system is turned off, the muting operation will be automatically cancelled.

Switching displays B

Press DISPLAY/DEMO.

Every time you press the button, the spectrum analyzer will change as shown on the left.

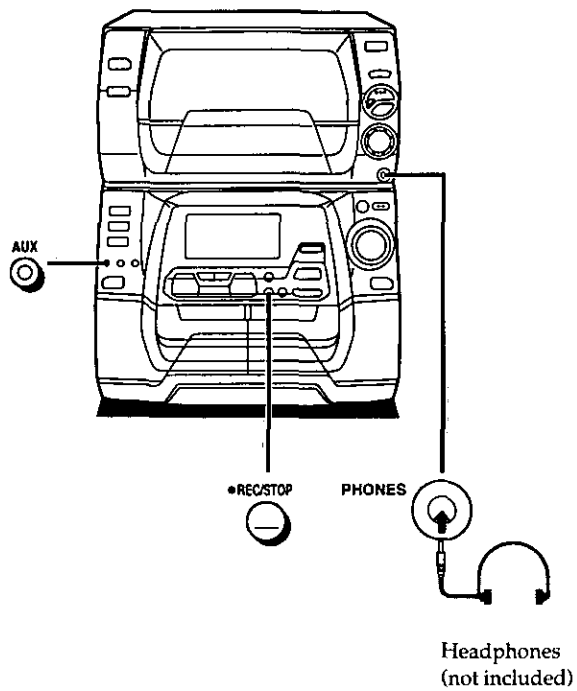

Using an external unit

Listening to an external source

(See page 7 for external unit connection.)

1. Press AUX.
The power will come on automatically.
2. Start playback from the external source. (Refer to your equipment's operating instructions.)

Recording from an external source

1. Follow steps 1–2 on page 22.
2. Press AUX.
3. Press ● REC/STOP (recording starts).
4. Start playback from the external source. (Refer to your equipment's operating instructions.)

Listening with headphones

Reduce the volume level, and connect the headphones.
Plug type: 3.5 mm (1/8 in) stereo

Note

Avoid listening for prolonged periods of time to prevent hearing damage.

Remote control buttons and functions

Reference pages are given as black circled numbers.

Reference

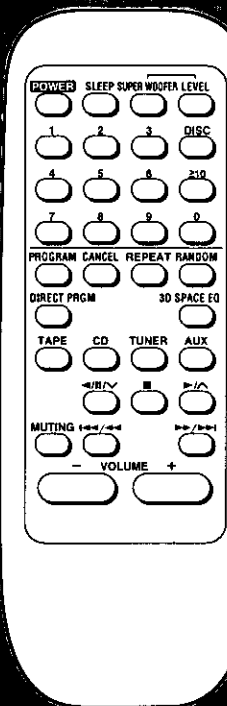

Button	Source	Radio	CD	Tape	Other component
		Turns the unit ON/OFF.			
		For setting sleep timer 33			
		For station selection (v, ^) (In PRESET mode) 11	Playback (▶) 13	Playback (◀, ▶) 20	—
			Pause () 13		—
		—	Stop 13, 20		—
		—	<ul style="list-style-type: none"> •Searching forward/backward 13 •Skipping forward/backward 13 	<ul style="list-style-type: none"> •Fast-forward/Rewind (While stopped) •Finding the beginning of a tune 21 	—
		For station selection (In PRESET mode) 11	<ul style="list-style-type: none"> •CD selection 14, 16 •Track selection 14, 16 	—	—
		—	CD select mode 14, 16	—	—
		—	Engages program input. 16	—	—
		—	Engages program input while listening to tracks 16	—	—
		—	Cancels program contents. 17	—	—
		—	For selecting repeat playback mode 15	—	—
		—	Random playback 15	—	—
		Input source selection 11, 13, 20, 35			
		<ul style="list-style-type: none"> •When the system is OFF One-touch playback begins by pressing TUNER, CD or TAPE. •When the system is ON Band can be switched with TUNER, and tape deck switched with TAPE. 			
		Sound quality/field ON/OFF and selection 27			
		SC-AK90/SC-AK91 only			
		For setting super woofer level 27			
		Mutes volume temporarily. 34			
		For setting volume 11, 13, 20			

Concerning CDs

With this changer, you can only play CDs having this mark.

However, do not use irregular shape CDs (heart-shape, octagonal, etc.). CDs of the sort can damage the unit. 



Handling precautions

Be sure to handle CDs according to the precautions shown on the left (**B-D**). Failure to do so may damage the CD or the CD changer unit.

- If you are taking the CD from a cold to a warm environment, moisture may form on the CD. Wipe this off with a soft, dry, lint-free cloth before using the CD.
- Do not write on the label side with a ball-point pen or other writing instrument.
- Do not use record cleaning sprays, benzine, thinner, static electricity prevention liquids or any other solvent.
- Do not attach labels or stickers to CDs. (Do not use CDs with exposed adhesive from tape or left over peeled off stickers.)
- Do not use scratch-proof protectors or covers other than those specified for use with this system.

Storage precautions

Be sure to store CDs in their cases to protect them from dust, scratches, and warping.

Do not place or store CDs in the following places

- Locations exposed to direct sunlight
- Humid or dusty locations
- Locations directly exposed to a heat vent or heating appliance
- In the glove compartment or on the rear deck of an automobile

Concerning cassette tapes

Selection of cassette tapes

Tapes can get caught on the capstans. Use caution with the following types of tapes.

Cassette tapes exceeding 100 minutes

Tapes are made of a thin film material. Do not repeatedly advance and stop the tape, fast-forward it or rewind it.

Endless-tapes

For this unit, it is recommended to use tapes which are appropriate to the auto reverse mechanism.

Always read the instructions provided with your tapes.

Tape slack

Tape slack may cause the tape to break.

Erase prevention

Storage precautions

Do not place or store tapes in the following places;

- In high temperature (35°C or higher) or high humidity (80% or higher) areas
- In a strong magnetic field (near a speaker, on top of a TV, etc.) This can erase a recording.
- Locations exposed to direct sunlight

A

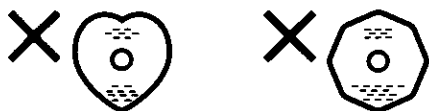

B

How to return CDs to their case

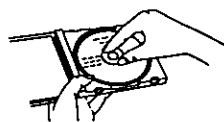

Face label upwards and press downward from above.

C

How to hold CDs

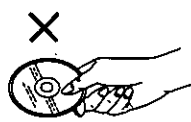
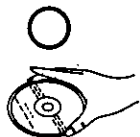

Do not touch the recorded surface

D

How to clean CDs

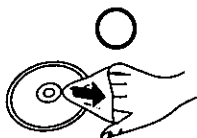

Wipe from inside outward.

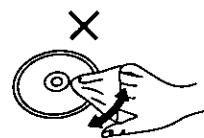

E

How to take up tape slack



Use a pencil or similar object to take up the slack.

F

To protect tapes against further recording

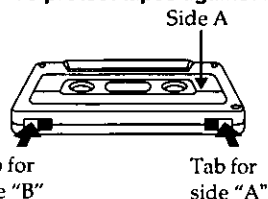

Tab for side "B"

Tab for side "A"

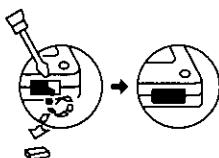

Use a screwdriver or similar object to break out the tab.

To re-record on a protected cassette

Cover the hole with adhesive tape

Normal position tape

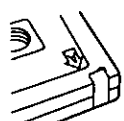

Do not cover the detection hole on hi-position tapes

Hi-position tape



Detection hole

Troubleshooting guide

Before requesting service for this unit, check the chart below for a possible cause of the problem you are experiencing. Some simple checks or a minor adjustment on your part may resolve the problem and restore proper operation.

If you are in doubt about some of the check points, or if the remedies indicated in the chart do not solve the problem, refer to the directory of Authorized Service Centers (enclosed with this unit) to locate a convenient service center, or consult your dealer for instructions. (In U.S.A consult PASC Authorized Servicenters for detailed instructions or call 1-800-545-2672 for the address of an authorized factory servicenter.)

Reference

Problem	Probable cause(s)	Suggested remedy
---------	-------------------	------------------

Problems common to all systems		
There is no sound when the power is ON.	Volume is set too low.	Adjust the volume level with the volume control. ① ② ③
The location of the various musical instruments is not well defined.	The (+) and (-) connections to one of the speakers are reversed.	Connect the speaker cords correctly. ⑥
The left and right sounds are reversed.	The left and right connections to the speaker are reversed.	Connect the speaker cords correctly. ⑥
When listening to the external unit, the left and right sounds are reversed.	The left and right connections to the external unit are reversed.	Connect the external unit's cord correctly. ⑦
Only one speaker is emitting sound.	One of the wires of the speaker cord is disconnected.	Connect the speaker cord correctly. ⑥
There is no sound when a source is being played.	The (+) and (-) wire of the speaker cords are shorted.	Switch the system to the standby mode, and reconnect the speaker cords so that they are not shorted. Then switch on the power. ⑥
"ERROR" message appears on the display.	Wrong operation has been done.	Operate the unit correctly by following the operating instructions.
"--:--" appears on the display	<ul style="list-style-type: none"> You plugged the power cord in for the first time. There was a power failure recently. 	Set the time. ⑧

While listenig to FM broadcasts		
There is a "rushing noise" during a stereo broadcast which is not audible during a monaural broadcast.	The transmitting station is a long distance away.	If you are using an indoor antenna, change to an outdoor antenna. ⑦
You hear excessive noise during a stereo broadcast, and occasionally the sound disappears.	The installation location and orientation of the antenna are unsuitable.	
The stereo indicator ("STEREO") flickers and does not light completely.	The transmitting station is a long distance away.	Try switching off the TV set or VCR.
	The power of the TV set or VCR is ON.	
The sound during a stereo broadcast is highly distorted.	There is a building or mountain nearby. [Distortion is caused by interference between the signal from the transmitting station (direct wave) and the signal reflected from the building or mountain (reflected wave).]	Use a high-grade outdoor antenna, and install it in a good location, height, and orientation for reception. ⑦

While listening to AM broadcasts		
You hear an unusual beat sound.	You are using the system at the same time you are playing a TV set.	Switch off the TV set, or use the system further away from it.
You hear a low-frequency hum.	The antenna wire is near the power cord.	Separate the antenna wire from the power cord.

Problem	Probable cause(s)	Suggested remedy
---------	-------------------	------------------

When there is a television set nearby

The picture on the TV disappears or stripes appear on the screen.	The location and orientation of the antenna are incorrect.	If you are using an indoor antenna, change to an outdoor antenna. ⑦
	The wiring at the back of the system is unsuitable.	Separate the antenna wire of the TV set from the system.

When listening to tapes

Sound is low, intermittent, poor quality, noisy, scratchy, Heads are dirty.	Heads are dirty.	Clean the heads. ④⑨
The deck does not enter the recording mode.	The erase-prevention tabs are removed from the cassette.	Attach tape to cover the space left by removal of the erase-prevention tabs. ④⑦

While listening to CDs

The display does not show the correct indication. CD play does not start when you press the play button.	The CD label is facing left.	Set the CD with the label facing right. ⑫
	The CD is dirty.	Wipe the CD with a soft cloth. ⑭
	The CD is scratched.	Replace the CD with a new one.
	The CD is badly warped.	
	The CD is nonstandard.	Replace the CD with a different one. ④⑦
	There is condensation inside the CD changer.	Wait for 60 minutes before using the CD changer.
A certain music passage can't be played correctly.	The CD is dirty.	Wipe the CD with a soft cloth. ⑭
The error message "DISC TAKE OUT" appears on the display and the changer stops operating.	A disc has been put in the slot of the CD in play.	Remove the CD whose number is displayed and close the rack panel.
The CD does not return to its slot. ("DISC TAKE OUT" appears on the display.)	Because of light or noise, the changer has detected a CD in the slot of the CD being played, even though it is empty.	Check whether another CD is in the slot or not. If not, hold down the ■ (stop) button for 4 seconds. The changer will then eject the CD. If this proves to be ineffective, contact the place of purchase.

While using the remot control

The system cannot be operated with the remote control.	The batteries are installed in the reverse polarity.	Re-insert the batteries in the correct polarity. ⑤
	The batteries are run-down.	Replace the batteries with new batteries. ⑤

Maintenance

If the surface are dirty

To clean this unit, wipe with a soft, dry cloth.
If the surfaces are extremely dirty, use a soft cloth dipped in a soap-and-water solution or a weak detergent solution.

- Never use alcohol, paint thinner, benzene, or chemically treated cloths to clean this unit.
- Before using chemically impregnated cloth, read the instructions that came with the cloth carefully.

For a cleaner crisper sound

We recommend that you periodically clean parts (the shaded portion in the figure below) the tape contacts like the heads.
Do not use any solution other than alcohol for head cleaning.

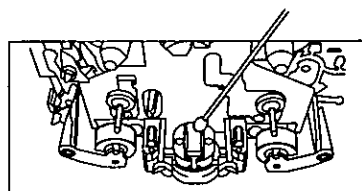

AMPLIFIER SECTION

SC-AK90/SC-AK91

Rated minimum sine wave	
RMS power output	
0.9% total harmonic distortion	
50 Hz–120 Hz both channels driven	75 W per channel (6Ω)
120 Hz–20 kHz both channels driven	25 W per channel (6Ω)
Total BI-AMP power	100 W per channel
Input sensitivity	
AUX	250 mV
MIC [SC-AK91 only]	0.6 mV
Input impedance	
AUX	15 kΩ
MIC [SC-AK91 only]	600Ω

AMPLIFIER SECTION

SC-AK70/SC-AK71

Rated minimum sine wave	
RMS power output	
0.9% total harmonic distortion	
50 Hz–12 kHz both channels driven	60 W per channel (6Ω)
1 kHz continuous power output	
both channels driven	
0.9% total harmonic distortion	70 W per channel (6Ω)
Input sensitivity	
AUX	250 mV
MIC [SC-AK71 only]	0.6 mV
Input impedance	
AUX	15 kΩ
MIC [SC-AK71 only]	600Ω

FM TUNER SECTION

Frequency range	
87.9–107.9 MHz (200 kHz steps)	
87.5–108.0 MHz (100 kHz steps)	
Sensitivity	23.3 dBf (4.0 μV, IHF '58)
Antenna terminal(s)	75Ω (unbalanced)

AM TUNER SECTION

Frequency range	520–1710 kHz
Sensitivity	
S/N 20 dB	500 μV/m

CASSETTE DECK SECTION

Track system	4 track, 2 channel
---------------------	--------------------

Heads

Record/playback	Solid permalloy head
Erasure	Double gap ferrite head
Motor	DC servo motor
Recording system	AC bias 100 kHz
Erasing system	AC erase
Tape speed	4.8 cm/s (17½ ips)
Frequency response	
(+3, –6 dB) at DECK OUT	
NORMAL	35 Hz–14 kHz
HIGH POSITION	35 Hz–14 kHz
S/N	50 dB (A weighted)
Wow and flutter	0.18% (WRMS)
Fast forward and rewind times	
	Approx. 120 seconds with C-60 cassette tape

CD SECTION

Sampling frequency	44.1 kHz
Decoding	16 bit linear
Beam source/wave length	Semiconductor laser/780 nm
Number of channels	Stereo
S/N	
SP OUT	87 dB (JIS.A)
Wow and flutter	Below measurable limit
Digital filter	8 fs
D/A converter	MASH (1 bit DAC)

SPEAKER SECTION

SC-AK90/SC-AK91

Type	4 way speaker system
Speaker(s)	
Super woofer	17 cm cone type
Woofer	12 cm cone type
Midrange	6 cm cone type
Tweeter	6 cm cone type
Impedance	HIGH (6Ω), LOW (6Ω)
Input power	
HIGH	80 W (MUSIC) 40 W (DIN)
LOW	200 W (MUSIC) 100 W (DIN)
Output sound pressure level	87 dB/W (1.0 m)
Cross over frequency	120 Hz, 4 kHz, 8 kHz
Frequency range	38 Hz–22 kHz (–16 dB)
	45 Hz–20 kHz (–10 dB)
Dimensions (W×H×D)	285×345×326 mm
	(11½"×13½"×12½")
Weight	6.2 kg (13.7 lb.)

SPEAKER SECTION

SC-AK70/SC-AK71

Type	3 way speaker system
Speaker(s)	
Woofer	14 cm cone type
Midrange	6 cm cone type
Tweeter	6 cm cone type
Impedance	6Ω
Input power	160 W (MUSIC), 80 W (DIN)
Output sound pressure level	85 dB/W (1.0 m)
Cross over frequency	2 kHz, 8 kHz
Frequency range	41 Hz–22 kHz (–16 dB)
	52 Hz–20 kHz (–10 dB)
Dimensions (W×H×D)	246×345×257 mm
	(9½"×13½"×10½")
Weight	3.3 kg (7.3 lb.)

GENERAL

Power supply	AC 120 V, 60 Hz
Power consumption	
	[SC-AK90/SC-AK91] 155 W
	[SC-AK70/SC-AK71] 125 W
Dimensions (W×H×D)	270×345×394 mm
	(10½"×13½"×15½")
Weight	
	[SC-AK90/SC-AK91] 10.3 kg (22.7 lb.)
	[SC-AK70/SC-AK71] 9.5 kg (20.9 lb.)

Notes:

- Specifications are subject to change without notice. Weight and dimensions are approximate.
- Total harmonic distortion is measured by the digital spectrum analyzer.

MASH is a trademark of NTT.

Product Service

Do not attempt to remove the cover(s) or repair the unit yourself. Refer servicing to qualified personnel only. The servicer will require all components to service your system. Therefore, should service ever be necessary, be sure to bring the entire system.

Product information

For product service, product information or assistance with product operation, refer to the servicer directory.

Before moving or shipping this system

Before moving your system to another location, be sure to remove all discs from the rack and turn off the system. The changer mechanism automatically locks when the system is turned off, to protect it against damage in transport. Therefore, always press POWER and make sure "GOOD BYE" appears on the display before you unplug the system. Failure to do so will expose the CDs and the system to the risk of severe damage.

Panasonic Consumer Electronics Company, Division of Matsushita Electric Corporation of America
One Panasonic Way Secaucus, New Jersey 07094

Panasonic Sales Company, Division of Matsushita Electric of Puerto Rico, Inc. ("PSC")
Ave. 65 de infanteria, Km. 9.5
San Gabriel Industrial Park, Carolina, Puerto Rico 00985

Panasonic Canada Inc.
5770 Ambler Drive, Mississauga, Ontario L4W 2T3